

10 Viscoelasticity

The Linear Elastic Solid has been the main material model analysed in this book thus far. It has a long history and is still the most widely used model in applications today.

Viscoelasticity is the study of materials which have a **time-dependence**. Vicat, a French engineer from the Department of Road Construction, noticed in the 1830's that bridge-cables continued to elongate over time even though under constant load, a viscoelastic phenomenon known as **creep**. Many other investigators, such as Weber and Boltzmann, studied viscoelasticity throughout the nineteenth century, but the real driving force for its study came later – the increased demand for power and the associated demand for materials which would stand up to temperatures and pressures that went beyond previous experience. By then it had been recognised that significant creep occurred in metals at high temperatures. The theory developed further with the emergence of synthetic polymer plastics, which exhibit strong viscoelastic properties. The study of viscoelasticity is also important in Biomechanics, since many biomaterials respond viscoelastically, for example, heart tissue, muscle tissue and cartilage.

Viscoelastic materials are defined in section 10.1 and some everyday viscoelastic materials and phenomena are discussed in section 10.2. The basic mechanical models of viscoelasticity, the Maxwell and Kelvin models, are introduced in section 10.3, as is the general differential equation form of the linear viscoelastic law. The hereditary integral form of the constitutive equation is discussed in section 10.4 and it is shown how the Laplace transform can be used to solve linear viscoelastic problems in section 10.5. In section 10.6, dynamic loading, impact and vibrations of viscoelastic materials are considered. Finally, in the last section, temperature effects are briefly discussed, including the important concept of thermorheologically simple materials.

10.1 The Response of Viscoelastic Materials

10.1.1 Viscoelastic Materials

The basic response of the viscoelastic material was discussed in section 5.3.2. Repeating what was said there, the typical response of a viscoelastic material is as sketched in Fig. 10.1.1. The following will be noted:

- (i) the loading and unloading curves do not coincide, Fig. 10.1.1a, but form a hysteresis loop
- (ii) there is a dependence on the rate of straining $d\varepsilon/dt$, Fig. 10.1.1b; the faster the stretching, the larger the stress required
- (iii) there may or may not be some permanent deformation upon complete unloading, Fig. 10.1.1a

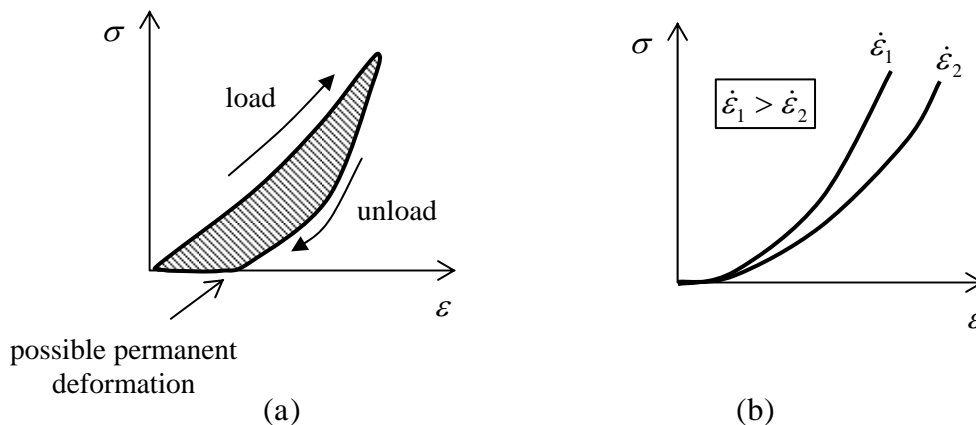

Figure 10.1.1: Response of a Viscoelastic material in the Tension test; (a) loading and unloading with possible permanent deformation (non-zero strain at zero stress), (b) different rates of stretching

The effect of *rate* of stretching shows that the viscoelastic material *depends on time*. This contrasts with the elastic material, whose constitutive equation is independent of time, for example it makes no difference whether an elastic material is loaded to some given stress level for one second or one day, or loaded slowly or quickly; the resulting strain will be the same.

It was shown in Chapter 5 that the area beneath the stress-strain curve is the energy per unit volume; during loading, it is the energy stored in a material, during unloading it is the energy recovered. There is a difference between the two for the viscoelastic material, indicated by the shaded region in Fig. 10.1.1a. This shaded region is a measure of the energy lost through heat transfer mechanisms during the deformation.

Most engineering materials undergo plasticity, meaning permanent deformations occur once the stress goes above the elastic limit. The stress-strain curve for these materials can look very similar to that of Fig. 10.1.1a, but, in contrast to viscoelasticity, plasticity is rate independent. Plasticity will be discussed in chapter 11.

Linear Viscoelasticity

Linear viscoelastic materials are those for which there is a linear relationship between stress and strain (at any given time), $\sigma \propto \varepsilon$. As mentioned before, this requires also that the strains are small, so that the engineering strain measure can be used (since the exact strain is inherently non-linear).

Strain-time curves for a linear viscoelastic material subjected to various constant stresses are shown in Fig. 10.1.2. At any given time, say t_1 , the strain is proportional to stress, so that the strain there due to $3\sigma_0$ is three times the strain due to σ_0 .

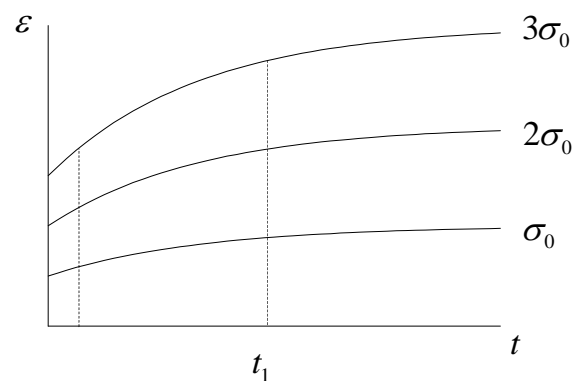

Figure 10.1.2: Strain as a function of time at different loads

Linear viscoelasticity is a reasonable approximation to the time-dependent behaviour of metals and ceramics at relatively low temperatures and under relatively low stress. However, its most widespread application is in the modelling of polymers.

10.1.2 Testing of Viscoelastic Materials

The tension test described in section 5.2 is the standard materials test. A number of other tests which are especially useful for the characterisation of viscoelastic materials have been developed, and these are discussed next.

The Creep and Recovery Test

The **creep-recovery test** involves loading a material at constant stress, holding that stress for some length of time and then removing the load. The response of a typical viscoelastic material to this test is shown in Fig. 10.1.3.

First there is an instantaneous elastic straining, followed by an ever-increasing strain over time known as **creep strain**. The creep strain usually increases with an ever decreasing strain rate so that eventually a more-or-less constant-strain steady state is reached, but many materials often do not reach such a noticeable steady-state, even after a very long time.

When unloaded, the elastic strain is recovered immediately. There is then **anelastic** recovery – strain recovered over time; this anelastic strain is usually very small for metals, but may be significant in polymeric materials. A permanent strain may then be left in the material¹.

A test which focuses on the loading phase only is simply called the **creep test**.

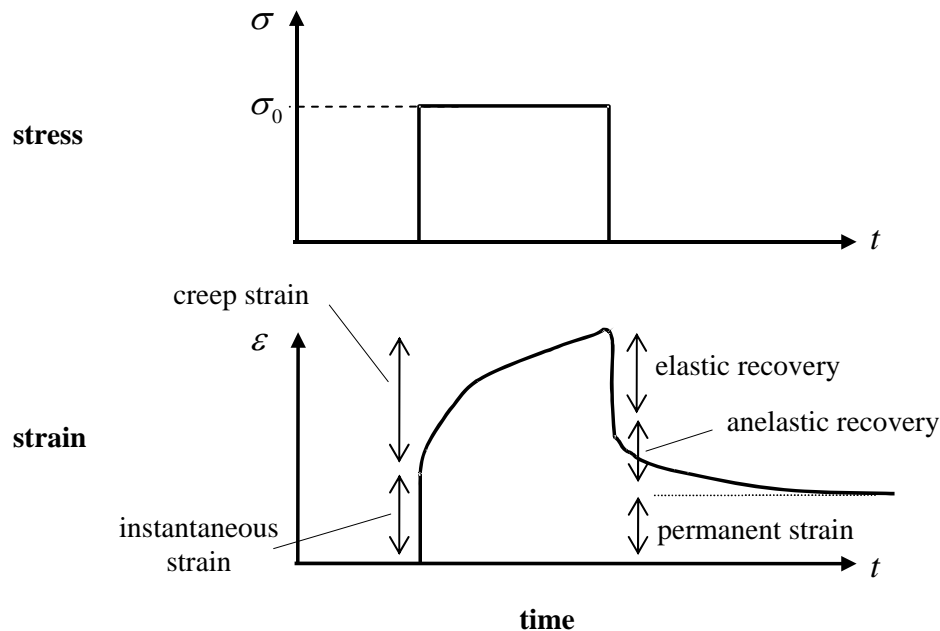

Figure 10.1.3: Strain response to the creep-recovery test

Stress Relaxation Test

The stress relaxation test involves straining a material at constant strain and then holding that strain, Fig. 10.1.4. The stress required to hold the viscoelastic material at the constant strain will be found to decrease over time. This phenomenon is called **stress relaxation**; it is due to a re-arrangement of the material on the molecular or micro-scale.

¹ if the load is above the yield stress, then some of the permanent deformation will be instantaneous plastic (rate-independent) strain; the subject of this chapter is confined to materials which are loaded up to a stress below any definable yield stress; rate-dependent materials with a yield stress above which permanent deformation take place, the viscoplastic materials, are discussed in Chapter 12

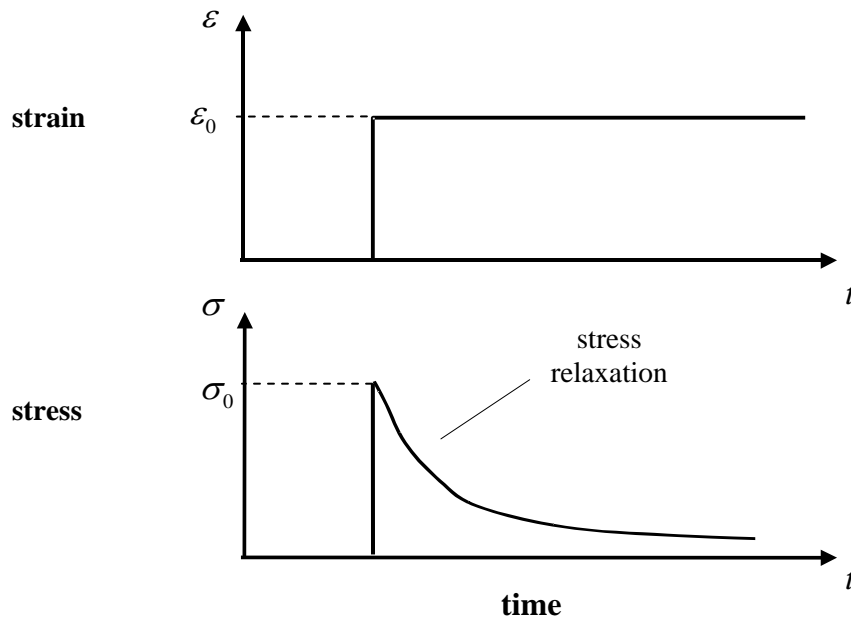

Figure 10.1.4: Stress response to the stress-relaxation test

The Cyclic Test

The cyclic test involves a repeating pattern of loading-unloading, Fig. 10.1.5 (see section 5.2.5). It can be strain-controlled (with the resulting stress observed), as in Fig. 10.1.5, or stress-controlled (with the resulting strain observed). The results of a cyclic test can be quite complex, due to the creep, stress-relaxation and permanent deformations.

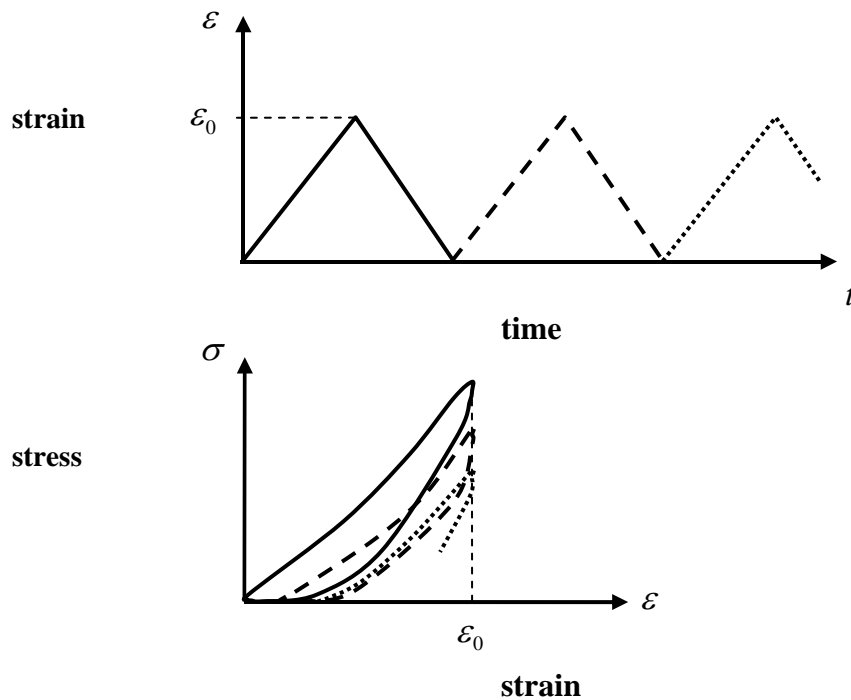

Figure 10.1.5: Typical stress response to the cyclic test

10.2 Examples and Applications of Viscoelastic Materials

Some of the properties of viscoelastic materials are their ability to creep, recover, undergo stress relaxation and absorb energy. Some examples of these phenomena are discussed in this section¹.

10.2.1 Creep and Recovery

The disks in the human spine are viscoelastic. Under normal body weight, the disks creep, that is they get shorter with time. Lying down allows the spinal disks to recover and this means that most people are taller in the morning than in the evening. Astronauts have gained up to 5cm in height under near-zero gravity conditions.

Skin tissue is viscoelastic. This can be seen by pinching the skin at the back of the hand; it takes time to recover back to its original flat position. The longer the skin is held in the pinched position, the longer it takes to recover. The more rapidly it is pinched, the less time it takes to recover – it behaves “more elastically”. Skin is an **ageing material**, that is, its physical properties change over time. Younger skin recovers more rapidly than older skin.

Wood is viscoelastic. The beams of old wooden houses can often be seen to sag, but this creeping under the weight of the roof and gravity can take many decades or centuries to be noticeable. Concrete and soils are other materials which creep, as is ice, which has consequences for glacial movements.

Materials which behave elastically at room temperature often attain significant viscoelastic properties when heated. Such is the case with metal turbine blades in jet engines, which reach very high temperatures and need to withstand very high tensile stresses. Conventional metals can creep significantly at high temperatures and this has led to the development of creep-resistant alloys; turbine blades are now often made of so-called superalloys which contain some or all of nickel, cobalt, chromium, aluminium, titanium, tungsten and molybdenum.

Creep is also one of the principal causes of failure in the electric light bulb. The filaments in light bulbs are made of tungsten, a metal with a very high melting point ($>3300^{\circ}\text{C}$); this is essential because the filament needs to be electrically heated to a temperature high enough for light emission ($\approx 2000^{\circ}\text{C}$). If the filament creeps too much it sags and its coils touch each other, leading to a localised short circuit. Light bulbs last longer if the temperature is reduced, as in dimmed lights. Creep can also be reduced by adding potassium bubbles to the tungsten.

Polymer foams used in seat cushions creep, allowing progressive conformation of the cushion to the body shape. These cushions help reduce the pressures on the body and are very helpful for people confined to wheelchairs or hospital beds for lengthy periods.

¹ quite a few of the applications and examples here are taken from *Viscoelastic Solids*, by R. S. Lakes, CRC Press, 1999

They often have to be replaced after about 6 months because creep causes them to become more dense and stiff.

A newly born baby's head is viscoelastic and its ability to creep and recover helps in the birthing process. Also, if a baby lies in one specific position for long, for example the same way of sleeping all the time, its head can become misshapen due to creep deformation. A baby's skull becomes more solid after about a year.

Viscoelasticity is also involved in the movement and behaviour of the tectonic plates, the plates which float on and travel independently over the mantle of the earth, and which are responsible for earthquakes, volcanoes, etc.

10.2.2 Stress Relaxation

Guitar strings are viscoelastic. When tightened they take up a tensile stress. However, when fixed at constant length (strain), stress relaxation occurs. The speed of sound in a string is $c = \sqrt{\sigma / \rho}$, where σ is the stress and ρ the density. The frequency is $f = c / \lambda$, where λ is the wavelength. The length of the string L is equal to half the wavelength: $f = \sqrt{\sigma / \rho} / (2L)$. The reduction in stress thus implies a reduction in frequency and a lowering of pitch – the guitar goes out of tune. The strings of a Classical Guitar are made of Nylon, a **synthetic polymer**. The great classical guitarists of the 19th Century did not have Nylon, invented in 1938, but used Catgut strings, usually made from the intestines of sheep; Catgut is a **natural polymer**. Metal guitar strings do not go out of tune so easily since metals are less viscoelastic than polymers.

10.2.3 Energy Absorption

Tall buildings vibrate when dynamically loaded by wind or earthquakes. Viscoelastic materials have the property of absorbing such vibrational energy – **damping** the vibrations. Viscoelastic dampers are used in some tall buildings, for example in the Columbia Center in Seattle, in which the dampers consist of steel plates coated with a viscoelastic polymer compound - the dampers are fixed to some of the diagonal bracing members.

Sometimes it is necessary to control vibrations but the use of a polymer is inappropriate - in this case it is necessary to use some other material with good vibration-control properties. A good example is the use of copper-manganese alloy to reduce vibration and noise from naval ship propellers. This alloy has also been used in pneumatic rock crushers. Zinc is also relatively viscoelastic for a metal and zinc-aluminium alloys are used in pneumatic drills - the alloy damps the vibrations and makes it a little less uncomfortable for anyone holding a pneumatic drill. Viscoelastic materials are also used to line the gloves worn by people working with pneumatic drills and jackhammers.

Helicopters make a lot of noise, which comes mainly from the turbine (rotary engine) and gears, but it is usually exacerbated by resonance of the fuselage skin. Acoustic blankets consisting of a layer of fibreglass sandwiched between layers of vinyl cloth, placed inside the fuselage, can reduce the noise. Sikorsky, in their HH-53C rescue helicopter, coated a

small portion of the fuselage skin with damping treatments, which helped reduce the high-frequency noise in the cabin by 10 dB.

In quartz watches, vibrations are set up in quartz crystal at ultrasonic frequency (32.768 kHz). The vibrations are then used to generate periodic signals, which may be divided into intervals of time, like the second. Quartz (SiO_2) is a very **low loss** material, meaning that it is very un-viscoelastic. This ensures that the vibrations are not dampened and the watch keeps good time.

Tuning forks are often made of aluminium as it is also a low-loss material. An aluminium tuning fork will continue vibrating for quite a long time after being struck – the vibrations eventually die down because of sound-energy loss, but also because of the small energy loss due to viscoelasticity within the aluminium fork.

Viscoelastic materials are excellent impact absorbers. A peak impact force can be reduced by a factor of two if an impact buffer is made of viscoelastic, rather than elastic, material. **Elastomers** are highly viscoelastic and make good impact absorbers; these are any of various substances resembling rubber - they have trade names like Sorbothane, Implus and Noene.

Viscoelastic materials are used in automobile bumpers, on computer drives to protect from mechanical shock, in helmets (the foam padding inside), in wrestling mats, etc. Viscoelastic materials are also used in shoe insoles to reduce impact transmitted to a person's skeleton.

The cartilage at the ends of the femur and tibia, in the knee joint, is a natural shock absorber. In an osteoarthritic knee, the cartilage has degraded – sometimes the bones grind against each other causing great pain. Synthetic viscoelastic materials can be injected directly into an osteoarthritic knee, enveloping cartilage-deficient joints and acting as a lubricant and shock absorber.

10.3 Rheological Models

In this section, a number of one-dimensional linear viscoelastic models are discussed.

10.3.1 Mechanical (rheological) models

The word viscoelastic is derived from the words "viscous" + "elastic"; a viscoelastic material exhibits both viscous and elastic behaviour – a bit like a fluid and a bit like a solid. One can build up a model of linear viscoelasticity by considering combinations of the linear elastic spring and the linear viscous dash-pot. These are known as **rheological models** or **mechanical models**.

The Linear Elastic Spring

The constitutive equation for a material which responds as a linear elastic spring of stiffness E is (see Fig. 10.3.1)

$$\varepsilon = \frac{1}{E} \sigma \quad (10.3.1)$$

The response of this material to a creep-recovery test is to undergo an instantaneous elastic strain upon loading, to maintain that strain so long as the load is applied, and then to undergo an instantaneous de-straining upon removal of the load.

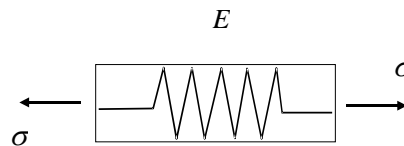

Figure 10.3.1: the linear elastic spring

The Linear Viscous Dash-pot

Imagine next a material which responds like a viscous dash-pot; the dash-pot is a piston-cylinder arrangement, filled with a viscous fluid, Fig. 10.3.2 – a strain is achieved by dragging the piston through the fluid. By definition, the dash-pot responds with a strain-rate proportional to stress:

$$\dot{\varepsilon} = \frac{1}{\eta} \sigma \quad (10.3.2)$$

where η is the **viscosity** of the material. This is the typical response of many **fluids**; the larger the stress, the faster the straining (as can be seen by pushing your hand through water at different speeds).

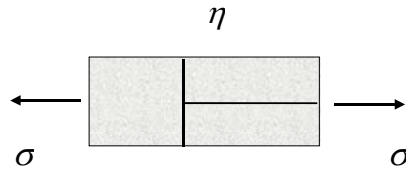

Figure 10.3.2: the linear dash-pot

The strain due to a suddenly applied load σ_o may be obtained by integrating the constitutive equation 10.3.2. Assuming zero initial strain, one has

$$\varepsilon = \frac{\sigma_o}{\eta} t \quad (10.3.3)$$

The strain is seen to increase linearly and without bound so long as the stress is applied, Fig. 10.3.3. Note that there is no movement of the dash-pot at the onset of load; it takes time for the strain to build up. When the load is removed, there is no stress to move the piston back through the fluid, so that any strain built up is permanent. The slope of the creep-line is σ_o / η .

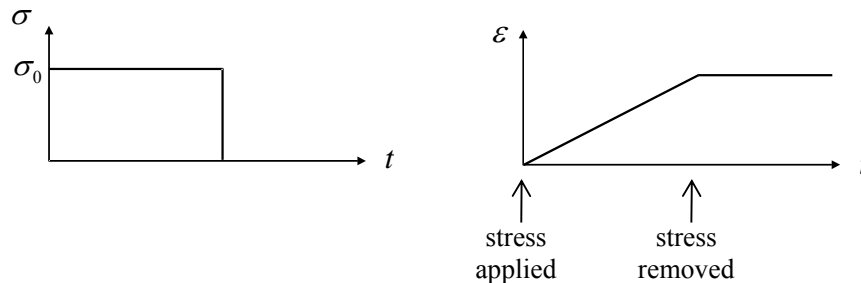

Figure 10.3.3: Creep-Recovery Response of the Dash-pot

The relationship between the stress and strain during the creep-test may be expressed in the form

$$\varepsilon(t) = \sigma_o J(t), \quad J(t) = \frac{t}{\eta} \quad (10.3.4)$$

J here is called the **creep (compliance) function** ($J = 1/E$ for the elastic spring).

10.3.2 The Maxwell Model

Consider next a spring and dash-pot in series, Fig. 10.3.4. This is the **Maxwell model**. One can divide the total strain into one for the spring (ε_1) and one for the dash-pot (ε_2).

Equilibrium requires that the stress be the same in both elements. One thus has the following three equations in four unknowns¹:

$$\varepsilon_1 = \frac{1}{E}\sigma, \quad \dot{\varepsilon}_2 = \frac{1}{\eta}\sigma, \quad \varepsilon = \varepsilon_1 + \varepsilon_2 \quad (10.3.5)$$

To eliminate ε_1 and ε_2 , differentiate the first and third equations, and put the first and second into the third:

$$\boxed{\sigma + \frac{\eta}{E}\dot{\sigma} = \eta\dot{\varepsilon}} \quad \text{Maxwell Model} \quad (10.3.6)$$

This constitutive equation has been put in what is known as **standard form** – stress on left, strain on right, increasing order of derivatives from left to right, and coefficient of σ is 1.

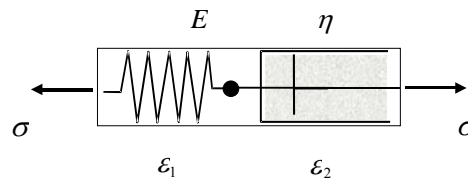

Figure 10.3.4: the Maxwell Model

Creep-Recovery Response

Consider now a creep test. Physically, when the Maxwell model is subjected to a stress σ_0 , the spring will stretch immediately and the dash-pot will take time to react. Thus the initial strain is $\varepsilon(0) = \sigma_0 / E$. Using this as the initial condition, an integration of 10.3.6 (with a zero stress-rate²) leads to

¹ If one considers an actual spring of length L_1 and a dashpot of length L_2 as in Fig. 10.3.4, and corresponding elongations d_1 and d_2 due to strains ε_1 and ε_2 , the total elongation would be $\varepsilon(L_s + L_d) = \varepsilon_s L_s + \varepsilon_d L_d$, which is not quite the same as Eqn. 10.3.5c. It is best to think of the Maxwell model as: the total strain at a material particle can be decomposed additively according to Eqn. 10.3.5c, with the separate strains being linear elastic and viscous; Fig. 10.3.4 is simply an attempt to visualise this concept.

² there is a jump in stress from zero to σ_0 when the load is applied, implying an infinite stress-rate $\dot{\sigma}$. One is not really interested in this jump here because the corresponding jump in strain can be predicted from the physical response of the spring. One is more interested in what happens just "after" the load is applied. In that sense, when one speaks of initial strains and stress-rates, one means their values at 0^+ , just after $t = 0$; the stress-rate is zero from 0^+ on. To be more precise, one can deal with the sudden jump in stress by integrating the constitutive equation across the point $t = 0$ as follows:

$$\begin{aligned} (E/\eta) \int_{-\Delta\tau}^{+\Delta\tau} \sigma(t) dt + \int_{-\Delta\tau}^{+\Delta\tau} \dot{\sigma}(t) dt &= E \int_{-\Delta\tau}^{+\Delta\tau} \dot{\varepsilon}(t) dt \\ \rightarrow (E/\eta) \int_{-\Delta\tau}^{+\Delta\tau} \sigma(t) dt + [\sigma(+\Delta\tau) - \sigma(-\Delta\tau)] &= E [\varepsilon(+\Delta\tau) - \varepsilon(-\Delta\tau)] \end{aligned}$$

In the limit as $\Delta\tau \rightarrow 0$, the integral tends to zero (σ is finite), the values of stress and strain at 0^- , i.e. in the limit as $\Delta\tau \rightarrow 0$ from the left, are zero. All that remains are the values to the right, giving

$$\begin{aligned}\dot{\varepsilon} = \frac{\sigma_o}{\eta} &\rightarrow \varepsilon(t) = \frac{\sigma_o}{\eta}t + C \\ &\rightarrow \varepsilon(t) = \sigma_o \left(\frac{1}{\eta}t + \frac{1}{E} \right)\end{aligned}\quad (10.3.7)$$

The creep-response can again be expressed in terms of a creep compliance function:

$$\varepsilon(t) = \sigma_o J(t) \quad \text{where} \quad J(t) = \frac{t}{\eta} + \frac{1}{E} \quad (10.3.8)$$

When the load is removed, the spring again reacts immediately, but the dash-pot has no tendency to recover. Hence there is an immediate elastic recovery σ_o / E , with the creep strain due to the dash-pot remaining. The full creep and recovery response is shown in Fig. 10.3.5.

The Maxwell model predicts creep, but not of the ever-decreasing strain-rate type. There is no anelastic recovery, but there is the elastic response and a permanent strain.

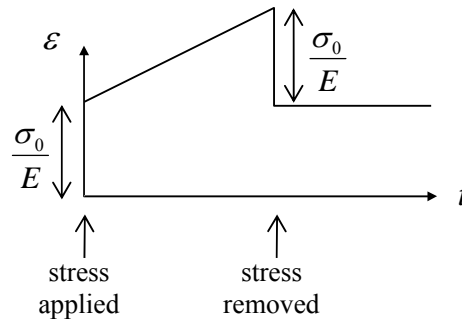

Figure 10.3.5: Creep-Recovery Response of the Maxwell Model

Stress Relaxation

In the stress relaxation test, the material is subjected to a constant strain ε_o at $t = 0$. The Maxwell model then leads to {▲ Problem 1}

$$\sigma(t) = \varepsilon_o E(t) \quad \text{where} \quad E(t) = Ee^{-t/t_R}, \quad t_R = \frac{\eta}{E} \quad (10.3.9)$$

Analogous to the creep function J for the creep test, $E(t)$ is called the **relaxation modulus** function.

$\sigma(0^+) = E\varepsilon(0^+)$, as expected. One can deal with this sudden behaviour more easily using integral formulations or with the Laplace Transform (see §10.4, §10.5)

The parameter t_R is called the **relaxation time** of the material and is a measure of the time taken for the stress to relax; the shorter the relaxation time, the more rapid the stress relaxation.

10.3.3 The Kelvin (Voigt) Model

Consider next the other two-element model, the **Kelvin (or Voigt) model**, which consists of a spring and dash-pot in parallel, Fig. 10.3.6. It is assumed there is no bending in this type of parallel arrangement, so that the strain experienced by the spring is the same as that experienced by the dash-pot. This time,

$$\varepsilon = \frac{1}{E}\sigma_1, \quad \dot{\varepsilon} = \frac{1}{\eta}\sigma_2, \quad \sigma = \sigma_1 + \sigma_2 \quad (10.3.10)$$

where σ_1 is the stress in the spring and σ_2 is the dash-pot stress. Eliminating σ_1, σ_2 leaves the constitutive law

$$\boxed{\sigma = E\varepsilon + \eta\dot{\varepsilon}} \quad \text{Kelvin (Voigt) Model} \quad (10.3.11)$$

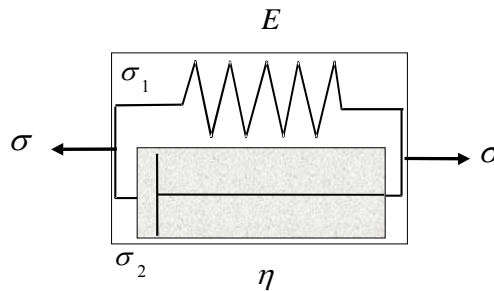

Figure 10.3.6: the Kelvin (Voigt) Model

Creep-Recovery Response

If a load σ_0 is applied suddenly to the Kelvin model, the spring will want to stretch, but is held back by the dash-pot, which cannot react immediately. Since the spring does not change length, the stress is initially taken up by the dash-pot. The creep curve thus starts with an initial slope σ_0 / η .

Some strain then occurs and so some of the stress is transferred from the dash-pot to the spring. The slope of the creep curve is now σ_2 / η , where σ_2 is the stress in the dash-pot, with σ_2 ever-decreasing. In the limit when $\sigma_2 = 0$, the spring takes all the stress and thus the maximum strain is σ_0 / E .

Solving the first order non-homogeneous differential equation 10.3.11 with the initial condition $\varepsilon(0) = 0$ gives

$$\varepsilon(t) = \frac{\sigma_o}{E} \left(1 - e^{-(E/\eta)t}\right) \quad (10.3.12)$$

which agrees with the above physical reasoning; the creep compliance function is now

$$J(t) = \frac{1}{E} \left(1 - e^{-t/t_R}\right), \quad t_R = \frac{\eta}{E} \quad (10.3.13)$$

The parameter t_R , in contrast to the relaxation time of the Maxwell model, is here called the **retardation time** of the material and is a measure of the time taken for the creep strain to accumulate; the shorter the retardation time, the more rapid the creep straining.

When the Kelvin model is unloaded, the spring will want to contract but again the dash pot will hold it back. The spring will however eventually pull the dash-pot back to its original zero position given time and full recovery occurs.

Suppose the material is unloaded at time $t = \tau$. The constitutive law, with zero stress, reduces to $0 = E\varepsilon + \eta\dot{\varepsilon}$. Solving leads to

$$\varepsilon(t) = Ce^{-(E/\eta)t} \quad (10.3.14)$$

where C is a constant of integration. The t here is measured from the point where "zero load" begins. If one wants to measure time from the onset of load, t must be replaced with $t - \tau$. From Eqn. 10.3.12, the strain at $t = \tau$ is $\varepsilon(\tau) = (\sigma_o / E)(1 - e^{-(E/\eta)\tau})$. Using this as the initial condition, one finds that

$$\varepsilon(t) = \frac{\sigma_o}{E} e^{-(E/\eta)t} \left(e^{(E/\eta)\tau} - 1\right), \quad t > \tau \quad (10.3.15)$$

The creep and recovery response is shown in Fig. 10.3.7. There is a transient-type creep and anelastic recovery, but no instantaneous or permanent strain.

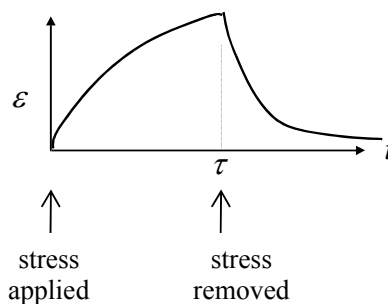

Figure 10.3.7: Creep-Recovery Response of the Kelvin (Voigt) Model

Stress Relaxation

Consider next a stress-relaxation test. Setting the strain to be a constant ε_0 , the constitutive law 10.3.11 reduces to $\sigma = E\varepsilon_0$. Thus the stress is taken up by the spring and is constant, so there is in fact no stress relaxation over time. Actually, in order that the Kelvin model undergoes an instantaneous strain of ε_0 , an infinite stress needs to be applied, since the dash-pot will not respond instantaneously to a finite stress³.

10.3.4 Three – Element Models

The Maxwell and Kelvin models are the simplest viscoelastic models. More realistic material responses can be modelled using more elements. The four possible three-element models are shown in Fig. 10.3.8 below. The models of Fig. 10.3.8a-b are referred to as “solids” since they react instantaneously as elastic materials and recover completely upon unloading. The models of Figs. 10.3.8c-d are referred to as “fluids” since they involve dashpots at the initial loading phase and do not recover upon unloading.

The differential constitutive relations for the Maxwell and Kelvin models were not to difficult to derive. However, even with three elements, deriving them can be a difficult task. This is because one needs to eliminate variables from a set of equations, one or more of which is a differential equation (for example, see 10.3.5). The task is more easily accomplished using integral formulations and the Laplace transform, which are discussed in §10.4-§10.5.

Only results are given here: the constitutive relations for the four models shown in Fig. 10.3.8 are

$$\begin{array}{l}
 \text{(a)} \quad \sigma + \frac{\eta}{E_1 + E_2} \dot{\sigma} = \frac{E_1 E_2}{E_1 + E_2} \varepsilon + \frac{\eta E_1}{E_1 + E_2} \dot{\varepsilon} \\
 \text{(b)} \quad \sigma + \frac{\eta}{E_2} \dot{\sigma} = E_1 \varepsilon + \frac{\eta(E_1 + E_2)}{E_2} \dot{\varepsilon} \\
 \text{(c)} \quad \sigma + \frac{\eta_2}{E} \dot{\sigma} = (\eta_1 + \eta_2) \dot{\varepsilon} + \frac{\eta_1 \eta_2}{E} \ddot{\varepsilon} \\
 \text{(d)} \quad \sigma + \frac{\eta_1 + \eta_2}{E} \dot{\sigma} = \eta_1 \dot{\varepsilon} + \frac{\eta_1 \eta_2}{E} \ddot{\varepsilon}
 \end{array} \tag{10.3.16}$$

The response of these models can be determined by specifying stress (strain) and solving the differential equations 10.3.16 for strain (stress).

³ the stress required is $\sigma(0) = \eta \varepsilon_0 \delta(t)$, where $\delta(t)$ is the Dirac delta function (this can be determined using the integral representations of §10.4)

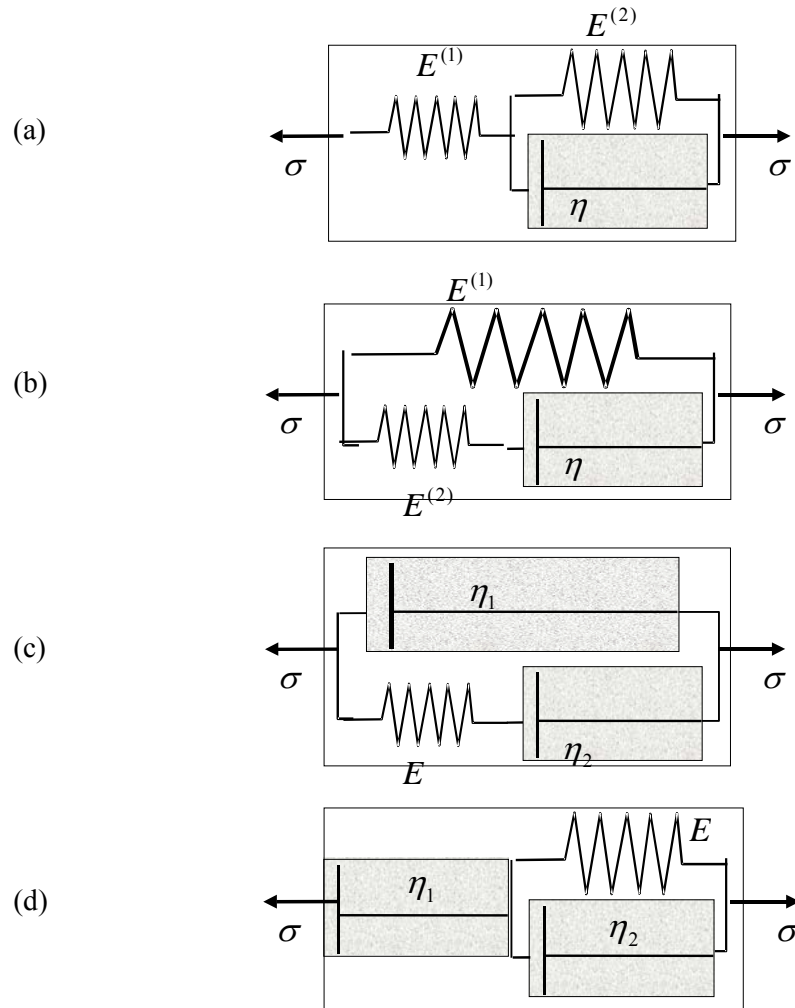

Figure 10.3.8: Three-element Models: (a) Standard Solid I, (b) Standard Solid II, (c) Standard Fluid I, (d) Standard Fluid II

10.3.5 The Creep Compliance and the Relaxation Modulus

The creep compliance function and the relaxation modulus have been mentioned in the context of the two-element models discussed above. More generally, they are defined as follows: the creep compliance is the strain due to unit stress:

$$\boxed{\varepsilon(t) = \sigma_o J(t), \quad \varepsilon(t) = J(t) \text{ when } \sigma_o = 1} \quad \text{Creep Compliance} \quad (10.3.17)$$

The relaxation modulus is the stress due to unit strain:

$$\boxed{\sigma(t) = \varepsilon_o E(t), \quad \sigma(t) = E(t) \text{ when } \varepsilon_o = 1} \quad \text{Relaxation Modulus} \quad (10.3.18)$$

Whereas the creep function describes the response of a material to a creep test, the relaxation modulus describes the response to a stress-relaxation test.

10.3.6 Generalized Models

More complex models can be constructed by using more and more elements. A complex viscoelastic rheological model will usually be of the form of the **generalized Maxwell model** or the **generalized Kelvin chain**, shown in Fig. 10.3.9. The generalized Maxwell model consists of N different Maxwell units in parallel, each unit with different parameter values. The absence of the isolated spring would ensure fluid-type behaviour, whereas the absence of the isolated dash-pot would ensure an instantaneous response. The generalised Kelvin chain consists of a chain of Kelvin units and again the isolated spring may be omitted if a fluid-type response is required.

In general, the more elements one has, the more accurate a model will be in describing the response of real materials. That said, the more complex the model, the more material parameters there are which need to be evaluated by experiment – the determination of a large number of material parameters might be a difficult, if not an impossible, task.

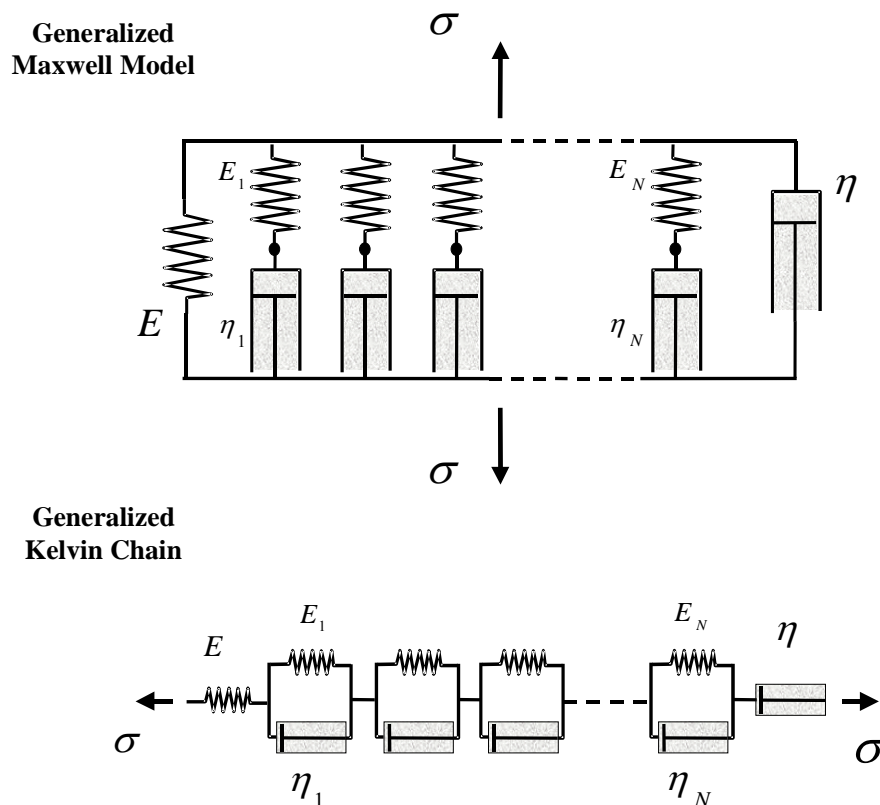

Figure 10.3.9: Generalised Viscoelastic Models

In general, a linear viscoelastic constitutive equation will be of the general form

$$p_0\sigma + p_1\dot{\sigma} + p_2\ddot{\sigma} + p_3\dddot{\sigma} + p_4\sigma^{(IV)} + \dots = q_0\varepsilon + q_1\dot{\varepsilon} + q_2\ddot{\varepsilon} + q_3\dddot{\varepsilon} + q_4\varepsilon^{(IV)} + \dots \quad (10.3.19)$$

The more elements (springs/dashpots) one uses, the higher the order of the differential equation.

Eqn. 10.3.19 is sometimes written in the short-hand notation

$$\mathbf{P}\sigma = \mathbf{Q}\varepsilon \quad (10.3.20)$$

where \mathbf{P} and \mathbf{Q} are the linear differential operators

$$\mathbf{P} = \sum_{i=0}^n p_i \frac{\partial^i}{\partial t^i}, \quad \mathbf{Q} = \sum_{i=0}^n q_i \frac{\partial^i}{\partial t^i} \quad (10.3.21)$$

A viscoelastic model can be created by simply entering values for the coefficients p_i , q_i , in 10.3.19, without referring to any particular rheological spring – dashpot arrangement. In that sense, springs and dashpots are not necessary for a model, all one needs is a differential equation of the form 10.3.19. However, the use of springs and dashpots is helpful as it gives one a physical feel for the way a material might respond, rather than simply using an abstract mathematical expression such as 10.3.19.

10.3.7 Non-Linear Models

More realistic material responses can be achieved by using non-linear models. For example, the springs of the previous section can be replaced with more general non-linear stress-strain relations of the form:

$$\sigma = E\varepsilon^n \quad (10.3.22)$$

Various non-linear expressions for dash-pots can also be used, for example,

$$\sigma = A\varepsilon^n \dot{\varepsilon}, \quad \sigma = Ae^{-\varepsilon/\varepsilon_0} \dot{\varepsilon} \quad (10.3.23)$$

Material data will certainly be better matched by such non-linear expressions; however, of course, they will result in non-linear differential equations which will be more difficult to solve than their linear counterparts.

10.3.8 Problems

1. Derive the Relaxation Modulus $E(t)$ for the Maxwell material.
2. What are the values of the coefficients p_i , q_i in the general differential equation 10.3.19 for
 - (a) the Maxwell model and the Kelvin model?
 - (b) The three-element models

10.3b Retardation and Relaxation Spectra

Generalised models can contain many parameters and will exhibit a whole array of relaxation and retardation times. For example, consider two Kelvin units in series, as in the generalised Kelvin chain; the first unit has properties E_1, η_1 and the second unit has properties E_2, η_2 . Using the methods discussed in §10.4-§10.5, it can be shown that the constitutive equation is

$$\sigma + \frac{\eta_1 + \eta_2}{E_1 + E_2} \dot{\sigma} = \frac{E_1 E_2}{E_1 + E_2} \varepsilon + \frac{E_1 \eta_2 + E_2 \eta_1}{E_1 + E_2} \dot{\varepsilon} + \frac{\eta_1 \eta_2}{E_1 + E_2} \ddot{\varepsilon} \quad (10.3.24)$$

Consider the case of specified stress, so that this is a second order differential equation in $\varepsilon(t)$. The homogeneous solution is {▲ Problem 3}

$$\varepsilon_h(t) = A e^{-t/t_R^1} + B e^{-t/t_R^2} \quad (10.3.25)$$

where $t_R^1 = \eta_1 / E_1, t_R^2 = \eta_2 / E_2$ are the eigenvalues of 10.3.24. For a constant load σ_0 , the full solution is {▲ Problem 3}

$$\varepsilon(t) = \sigma_0 \left[\frac{1}{E_1} \left(1 - e^{-t/t_R^1} \right) + \frac{1}{E_2} \left(1 - e^{-t/t_R^2} \right) \right] \quad (10.3.26)$$

Thus, whereas the single Kelvin unit has a single retardation time, Eqn. 10.3.13, this model has two retardation times, which are the eigenvalues of the differential constitutive equation. The term inside the square brackets is evidently the creep compliance of the model.

Note that, for constant strain, the model predicts a static response with no stress relaxation (as in the single Kelvin model).

In a similar way, for N units, it can be shown that the response of the generalised Kelvin chain to a constant load σ_0 is, neglecting the effect of the free spring/dashpot, of the form

$$\varepsilon(t) = \sigma_0 \sum_{i=1}^N \frac{1}{E_i} \left(1 - e^{-t/t_R^i} \right), \quad t_R^i = \frac{\eta_i}{E_i} \quad (10.3.27)$$

where E_i, η_i are the spring stiffness and dashpot viscosity of Kelvin element i , $i = 1 \dots N$, Fig. 10.3.9. The response of real materials can be modelled by allowing for a number of different retardation times of different orders of magnitude, e.g. $t_R^i = \{ \dots, 10^{-1}, 1, 10^1, 10^2, \dots \}$.

If one considers many elements, Eqn. 10.3.27 can be expressed as

$$\varepsilon(t) = \sigma_0 \sum_{i=1}^N \Delta \varphi(t_R^i) \left(1 - e^{-t/t_R^i} \right), \quad \Delta \varphi(t_R^i) = \frac{1}{\eta_i} t_R^i \quad (10.3.28)$$

If one is to obtain the same order of magnitude of strain for applied stress, these $\Delta\phi$'s will have to get smaller and smaller for increasing number of Kelvin units. In the limit as $N \rightarrow \infty$, letting $d\phi = (d\phi/dt_R)dt_R$, one has, changing the dummy variable of integration from dt_R to λ , and letting $\phi(t_R) = d\phi/dt_R$,

$$\varepsilon(t) = \sigma_0 \int_0^{\infty} \phi(\lambda) (1 - e^{-t/\lambda}) d\lambda \quad (10.3.29)$$

The representation 10.3.29 allows for a continuous retardation time, in contrast to the discrete times of the model 10.3.27. The function $\phi(\lambda)$ is called the **retardation spectrum** of the model. Different responses can be modelled by simply choosing different forms for the retardation spectrum.

An alternative form of Eqn. 10.3.29 is often used, using the fact that $d\lambda/d(\ln \lambda) = \lambda$:

$$\varepsilon(t) = \sigma_0 \int_0^{\infty} \bar{\phi}(\lambda) (1 - e^{-t/\lambda}) d(\ln \lambda) \quad (10.3.30)$$

where $\bar{\phi} = \lambda\phi$.

A similar analysis can be carried out for the Generalised Maxwell model. For two Maxwell elements in parallel, the constitutive equation can be shown to be

$$\sigma + \frac{E_1\eta_2 + E_2\eta_1}{E_1E_2} \dot{\sigma} + \frac{\eta_1\eta_2}{E_1E_2} \ddot{\sigma} = (\eta_1 + \eta_2)\dot{\varepsilon} + \frac{E_1 + E_2}{E_1E_2} \eta_1\eta_2 \ddot{\varepsilon} \quad (10.3.31)$$

Consider the case of specified strain, so that this is a second order differential equation in $\sigma(t)$. The homogeneous solution is, analogous to 10.3.25, {▲ Problem 4}

$$\sigma_h(t) = Ae^{-t/t_R^1} + Be^{-t/t_R^2} \quad (10.3.32)$$

where again $t_R^1 = \eta_1/E_1$, $t_R^2 = \eta_2/E_2$, and are the eigenvalues of 10.3.31. For a constant strain ε_0 , the full solution is {▲ Problem 4}

$$\sigma(t) = \varepsilon_0 \left[E_1 e^{-t/t_R^1} + E_2 e^{-t/t_R^2} \right] \quad (10.3.33)$$

Thus, whereas the single Maxwell unit has a single relaxation time, Eqn. 10.3.9, this model has two relaxation times, which are the eigenvalues of the differential constitutive equation. The term inside the square brackets is evidently the relaxation modulus of the model.

By considering a model with an indefinite number of Maxwell units in parallel, each with vanishingly small elastic moduli ΔE_i , one has the expression analogous to 10.3.29,

$$\sigma(t) = \varepsilon_0 \int_0^{\infty} \mathcal{G}(t_R) e^{-t/t_R} dt_R \quad (10.3.34)$$

and $\mathcal{G}(t_R)$ is called the **relaxation spectrum** of the model.

To complete this section, note that, for the two Maxwell units in parallel, a constant stress σ_0 leads to the creep strain {▲Problem 5}

$$\varepsilon(t) = \sigma_0 \left[\frac{1}{E_1 + E_2} e^{-t/t_R} + \left(\frac{\eta_1 / E_1 + \eta_2 / E_2}{\eta_1 + \eta_2} - \frac{t_R}{\eta_1 + \eta_2} \right) (1 - e^{-t/t_R}) + \frac{t}{\eta_1 + \eta_2} \right], \quad (10.3.35)$$

$$t_R = \frac{\eta_1 \eta_2}{\eta_1 + \eta_2} \frac{E_1 + E_2}{E_1 E_2}$$

Problems

3. Consider two Kelvin units in series, as in the generalised Kelvin chain; the first unit has properties E_1, η_1 and the second unit has properties E_2, η_2 . The constitutive equation is given by Eqn. 10.3.24.
 - (a) The homogeneous equation is of the form $A\ddot{\varepsilon} + B\dot{\varepsilon} + C\varepsilon = 0$. By considering the characteristic equation $A\lambda^2 + B\lambda + C = 0$, show that the eigenvalues are $\lambda = -E_1 / \eta_1, -E_2 / \eta_2$ and hence that the homogeneous solution is 10.3.25.
 - (b) Consider now a constant load σ_0 . Show that the particular solution is $\varepsilon(t) = \sigma_0 (E_1 + E_2) / E_1 E_2$.
 - (c) One initial condition of the problem is that $\varepsilon(0) = 0$. The second condition results from the fact that only the dashpots react at time $t = 0$ (equivalently, one can integrate the constitutive equation across $t = 0$ as in the footnote in §10.3.2). Show that this condition leads to $\dot{\varepsilon}(0) = \sigma_0 (\eta_1 + \eta_2) / \eta_1 \eta_2$.
 - (d) Use the initial conditions to show that the constants in 10.3.24 are given by $A = -\sigma_0 / E_1, B = -\sigma_0 / E_2$ and hence that the complete is given by 10.3.26.
 - (e) Consider again the constitutive equation 10.3.24. What values do the constants E_2, η_2 take so that it reduces to the single Kelvin model, Eqn. 10.3.11.

4. Consider two Maxwell units in parallel, as in the generalised Maxwell model; the first unit has properties E_1, η_1 and the second unit has properties E_2, η_2 . The constitutive equation is given by Eqn. 10.3.31.
 - (a) Suppose we have a prescribed strain history and we want to determine the stress. The homogeneous equation is of the form $A\ddot{\sigma} + B\dot{\sigma} + C\sigma = 0$. By considering the characteristic equation $A\lambda^2 + B\lambda + C = 0$, show that the eigenvalues are $t_R^1 = \eta_1 / E_1, t_R^2 = \eta_2 / E_2$ and hence that the homogeneous solution is 10.3.32.
 - (b) Consider now a constant load ε_0 . Show that the particular solution is zero.
 - (c) One initial condition results from the fact that only the springs react at time $t = 0$, which leads to the condition $\sigma(0) = \varepsilon_0 (E_1 + E_2)$. A second condition can be

obtained by integrating the constitutive equation across $t = 0$ as in the footnote in §10.3.2. Show that this leads to the condition $\dot{\sigma}(0^+) = -(E_1^2/\eta_1 + E_2^2/\eta_2)\varepsilon_0$.

- (d) Use the initial conditions to show that the constants in 10.3.32 are given by $A = E_1\varepsilon_0$, $B = E_2\varepsilon_0$ and hence that the complete solution is given by 10.3.33.
- (e) Consider again the constitutive equation 10.3.31. What values do the constants E_2, η_2 take so that it reduces to the single Maxwell model, Eqn. 10.3.6.

5. Consider again the two Maxwell units in parallel, as in Problem 4. This time consider a stress-driven problem.

- (a) From the constitutive equation 10.3.31, the differential equation to be solved is of the form $A\dot{\varepsilon} + B\varepsilon = \dots$. By considering the characteristic equation $A\lambda^2 + B\lambda = 0$, show that the eigenvalues are

$$\lambda_1 = 0, \lambda_2 = -\frac{(\eta_1 + \eta_2)E_1E_2}{\eta_1\eta_2(E_1 + E_2)}$$

and hence that the homogeneous solution is $\varepsilon(t) = C_1 + C_2e^{-t/t_R}$ where $t_R = -1/\lambda_2$.

- (b) Consider now a constant stress σ_0 . By using the condition that only the springs react at time $t = 0$, show that the particular solution is $\sigma_0 t / (\eta_1 + \eta_2)$.
- (c) One initial condition results from the fact that only the springs react at time $t = 0$, which leads to the condition $\varepsilon(0) = \sigma_0 / (E_1 + E_2)$. A second condition can be obtained by integrating the constitutive equation across $t = 0$ as in the footnote in §10.3.2. Be careful to consider all terms in 10.3.31. Show that this leads to the condition

$$\dot{\varepsilon}(0^+) = (\sigma_0 / t_R) \left[(\eta_1 / E_1 + \eta_2 / E_2) / (\eta_1 + \eta_2) - 1 / (E_1 + E_2) \right].$$

- (d) Use the initial conditions to show that the complete solution is given by 10.3.35.

10.4 The Hereditary Integral

In the previous section, it was shown that the constitutive relation for a linear viscoelastic material can be expressed in the form of a linear differential equation, Eqn. 10.3.19. Here it is shown that the stress-strain relation can also be expressed in the form of an integral, called the **hereditary integral**. Quite a few different forms of this integral are commonly used; to begin this section, the different forms are first derived for the Maxwell model, before looking at the more general case(s).

10.4.1 An Example: the Maxwell Model

Consider the differential equation for the Maxwell model, Eqn. 10.3.6,

$$\frac{d\sigma}{dt} + \frac{E}{\eta}\sigma = E \frac{d\varepsilon}{dt} \quad (10.4.1)$$

The first order differential equation can be solved using the standard **integrating factor** method. This converts 10.4.1 into an integral equation. Three similar integral equations will be derived in what follows¹.

Hereditary Integral over $[-\infty, t]$

It is sometimes convenient to regard 10.4.1 as a differential equation over the time interval $[-\infty, t]$, even though the time interval of interest is really $[0, t]$. This can make it easier to deal with sudden “jumps” in stress or strain at time $t = 0$. The initial condition on 10.4.1 is then

$$\sigma(-\infty) = 0. \quad (10.4.2)$$

Using the integrating factor $e^{Et/\eta}$, re-write 10.4.1 in the form

$$\frac{d}{dt} \left(e^{Et/\eta} \sigma(t) \right) = E e^{Et/\eta} \frac{d\varepsilon(t)}{dt} \quad (10.4.3)$$

Integrating both sides over $[-\infty, \hat{t}]$ gives

$$\left(e^{Et/\eta} \sigma \right)_i - \left(e^{Et/\eta} \sigma \right)_{-\infty} = \int_{-\infty}^{\hat{t}} E e^{Et/\eta} \frac{d\varepsilon(t)}{dt} dt \quad (10.4.4)$$

or

¹ note that Eqn. 10.4.1 predicts that sudden changes in the strain-rate, $\dot{\varepsilon}$, will lead to sudden changes in the stress-rate, $\dot{\sigma}$, but the stress σ will remain continuous. The strain ε does not appear explicitly in 10.4.1; sudden changes in strain can be dealt with by (i) integrating across the point where the jump occurs, or (ii) using step functions and the integral formulation (see later)

$$\sigma(\hat{t}) = \int_{-\infty}^{\hat{t}} E e^{-E(\hat{t}-t)/\eta} \frac{d\varepsilon(t)}{dt} dt \quad (10.4.5)$$

Changing the notation,

$$\sigma(t) = \int_{-\infty}^t E(t-\tau) \frac{d\varepsilon(\tau)}{d\tau} d\tau \quad (10.4.6)$$

where $E(t)$, the relaxation modulus for the Maxwell model, is

$$E(t) = E e^{-Et/\eta} \quad (10.4.7)$$

This is known as a hereditary integral; given the **strain history** over $[-\infty, t]$, one can evaluate the stress at the current time. It is the *same* constitutive equation as Eqn. 10.4.1, only in a different form.

Hereditary Integral over $[0, t]$

The hereditary integral can also be expressed in terms of an integral over $[0, t]$. Let there be a sudden non-zero strain $\varepsilon(0)$ at $t = 0$, with the strain possibly varying, but continuously, thereafter. The strain, which in Eqn. 10.4.6 is to be regarded as a single function over $[-\infty, t]$ with a jump at $t = 0$, is sketched in Fig. 10.4.1.

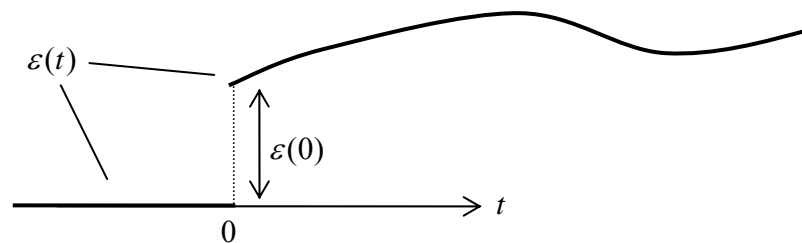

Figure 10.4.1: Strain with a sudden jump to a non-zero strain at $t = 0$

There are two ways to proceed. First, write the integral over three separate intervals:

$$\sigma(t) = \lim_{g \rightarrow 0} \left\{ \int_{-\infty}^{-g} E(t-\tau) \frac{d\varepsilon(\tau)}{d\tau} d\tau + \int_{-g}^{+g} E(t-\tau) \frac{d\varepsilon(\tau)}{d\tau} d\tau + \int_{+g}^t E(t-\tau) \frac{d\varepsilon(\tau)}{d\tau} d\tau \right\} \quad (10.4.8)$$

With $\varepsilon(t) = 0$ over $[-\infty, -g]$, the first integral is zero. With a jump in strain only at $t = 0$, the integrand in the third integral remains finite. The second integral can be evaluated by considering the function $f(t)$ illustrated in Fig. 10.4.2, a straight line with slope $\varepsilon(0)/2g$. As $g \rightarrow 0$, it approaches the actual strain function $\varepsilon(t)$, which jumps to $\varepsilon(0)$ at $t = 0$. Then

$$\lim_{g \rightarrow 0} \int_{-g}^{+g} E(t-\tau) \frac{d\varepsilon(\tau)}{d\tau} d\tau = \lim_{g \rightarrow 0} \frac{\varepsilon(0)}{2g} \eta e^{-Et/\eta} (e^{+Eg/\eta} - e^{-Eg/\eta}) \quad (10.4.9)$$

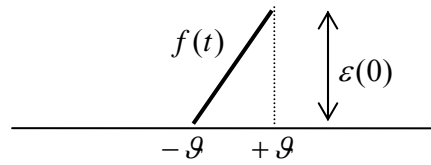

Figure 10.4.2: A function used to approximate the strain for a sudden jump

Using the approximation $e^x \approx 1 + x$ for small x , the value of this integral is $\varepsilon(0)Ee^{-Et/\eta}$. Thus Eqn. 10.4.6 can be expressed as

$$\sigma(t) = E(t)\varepsilon(0) + \int_0^t E(t-\tau) \frac{d\varepsilon(\tau)}{d\tau} d\tau \quad (10.4.10)$$

By “0” here in the lower limit of the integral, one means 0^+ , just after any possible non-zero initial strain. In that sense, the strain $\varepsilon(t)$ in Eqn. 10.4.10 is to be regarded as a continuous function, i.e. with no jumps over $[0, t]$. Jumps in strain after $t = 0$ can be dealt with in a similar manner.

A second and more elegant way to arrive at Eqn. 10.4.10 is to re-express the above analysis in terms of the Heaviside step function $H(t)$ and the Dirac delta function $\delta(t)$ (see the Appendix to this section for a discussion of these functions).

The function sketched in Fig. 10.4.1 can be expressed as $H(t)\varepsilon(t)$ where now $\varepsilon(t)$ is to be regarded as a continuous function over $[-\infty, t]$ – the jump is now contained within the step function $H(t)$. Eqn. 10.4.6 now becomes

$$\sigma(t) = \int_{-\infty}^t E(t-\tau) \frac{d\varepsilon(\tau)}{d\tau} d\tau + \int_{-\infty}^t E(t-\tau)\varepsilon(\tau) \frac{dH(\tau)}{d\tau} d\tau \quad (10.4.11)$$

The first integral becomes the integral in 10.4.10. From the brief discussion in the Appendix to this section, the second integral becomes

$$\int_{-\infty}^t E(t-\tau)\varepsilon(\tau) \frac{dH(\tau)}{d\tau} d\tau = \int_{-\infty}^t E(t-\tau)\varepsilon(\tau)\delta(\tau) d\tau = E(t)\varepsilon(0) \quad (10.4.12)$$

A Third Hereditary Integral

Finally, the integral can also be expressed as a function of $\varepsilon(t)$, rather than its derivative. To achieve this, one can integrate 10.4.10 by parts:

$$\sigma(t) = E(0)\varepsilon(t) + \int_0^t \frac{dE(t-\tau)}{d(t-\tau)} \varepsilon(\tau) d\tau \quad (10.4.13)$$

This can be expressed as

$$\boxed{\sigma(t) = E(0)\varepsilon(t) - \int_0^t R(t-\tau)\varepsilon(\tau) d\tau} \quad (10.4.14)$$

where $R(t) = -dE(t)/dt$.

Note that integration by parts is only possible when there are no “jumps” in the functions under the integral sign and this is assumed for the integrand in 10.4.10. If there are jumps, the integral can either be split into separate integrals as in 10.4.8, or the functions can be represented in terms of step functions, which automatically account for jumps.

The formulae 10.4.6, 10.4.10 and 10.4.14 give the stress as functions of the strain. Similar formulae can be derived for the strain in terms of the stress (see the Appendix to this Section).

Relaxation Test

To illustrate the use of the hereditary integral formulae, consider a relaxation test, where the strain history is given by

$$\varepsilon(t) = \begin{cases} 0, & t < 0 \\ \varepsilon_0, & \text{otherwise} \end{cases} \quad (10.4.15)$$

Expressing the strain history as $\varepsilon(t) = \varepsilon_0 H(t)$, Eqn. 10.4.6 gives

$$\sigma(t) = \varepsilon_0 \int_{-\infty}^t E(t-\tau) \delta(\tau) d\tau = \varepsilon_0 E(t) \quad (10.4.16)$$

From 10.4.10, with the derivative in the integrand zero, one has $\sigma(t) = E(t)\varepsilon(0) = \varepsilon_0 E(t)$. Finally, from 10.4.14, with $R(t) = +(E^2/\eta)e^{-Et/\eta}$, one again has

$$\sigma(t) = E\varepsilon_0 - \varepsilon_0 \int_0^t \frac{E^2}{\eta} e^{-E(t-\tau)/\eta} d\tau = \varepsilon_0 E e^{-Et/\eta} = \varepsilon_0 E(t) \quad (10.4.17)$$

10.4.2 Hereditary Integrals: General Formulation

Although derived for the Maxwell mode, these formulae Eqns. 10.4.6, 10.4.10, 10.4.14, are in fact quite general, for example they can be derived from the differential equation for the Kelvin model (see Appendix to this section).

The hereditary integrals were derived directly from the Maxwell model differential equation so as to emphasize that they are one and the same constitutive equation. Here they are derived more generally from first principles.

The strain due to a constant step load $\sigma(0)$ applied at time $t = 0$ is by definition $\varepsilon(t) = \sigma(0)J(t)$, where $J(t)$ is the creep compliance function. The strain due to a second load, $\Delta\sigma$ say, applied at some later time τ , is $\varepsilon(t) = \Delta\sigma J(t - \tau)$. The total strain due to both loads is², Fig. 10.4.3,

$$\varepsilon(t) = \sigma(0)J(t) + \Delta\sigma J(t - \tau) \quad (10.4.18)$$

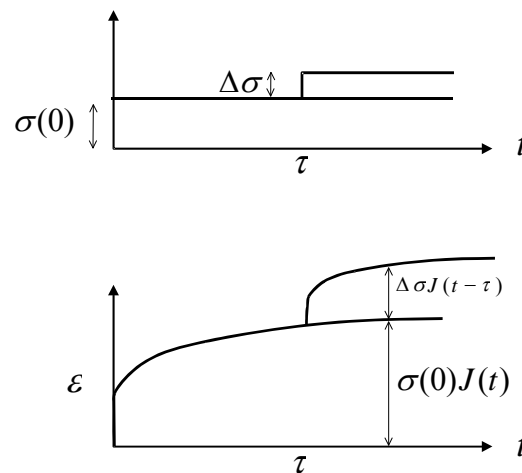

Figure 10.4.3: Superposition of loads

Generalising to an indefinite number of applied loads of infinitesimal magnitude, $d\sigma_i$, one has

$$\varepsilon(t) = \sigma(0)J(t) + \sum_{i=1}^{\infty} d\sigma_i J(t - \tau_i) \quad (10.4.19)$$

In the limit, the summation becomes the integral $\int J(t - \tau)d\sigma$, or³ (see Fig. 10.4.4)

$$\boxed{\varepsilon(t) = \sigma(0)J(t) + \int_0^t J(t - \tau) \frac{d\sigma(\tau)}{d\tau} d\tau} \quad \text{Hereditary Integral (for Strain)} \quad (10.4.20)$$

² this is again an application of the linear superposition principle, mentioned in §6.1.2; because the material is linear (and only because it is linear), the "effect" of a sum of "causes" is equal to the sum of the individual "effects" of each "cause"

³ this integral equation allows for a sudden non-zero stress at $t = 0$. Other jumps in stress at later times can be allowed for in a similar manner – one would split the integral into separate integrals at the point where the jump occurs

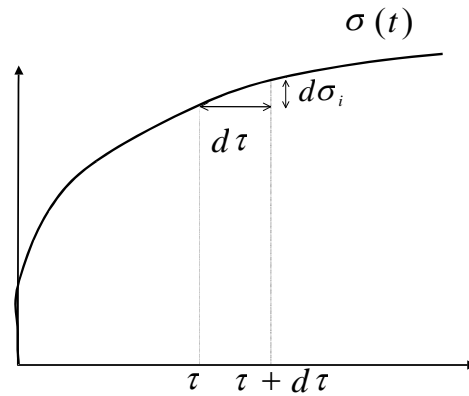

Figure 10.4.4: Formation of the hereditary integral

One can also derive a corresponding hereditary integral in terms of the relaxation modulus {▲ Problem 1}:

$$\sigma(t) = \varepsilon(0)E(t) + \int_0^t E(t-\tau) \frac{d\varepsilon(\tau)}{d\tau} d\tau \quad \text{Hereditary Integral (for Stress) (10.4.21)}$$

This is Eqn. 10.4.10, which was derived specifically from the Maxwell model.

The hereditary integrals only require a knowledge of the creep function (or relaxation function). One does not need to construct a rheological model (with springs/dashpots) to determine a creep function. For example, the creep function for a material may be determined from test-data from a creep test. The hereditary integral formulation is thus not restricted to particular combinations of springs and dash-pots.

Example

Consider the Maxwell model and the two load histories shown in Fig. 10.4.5. The maximum stress is the same in both, $\hat{\sigma}$, but load (1) is applied more gradually.

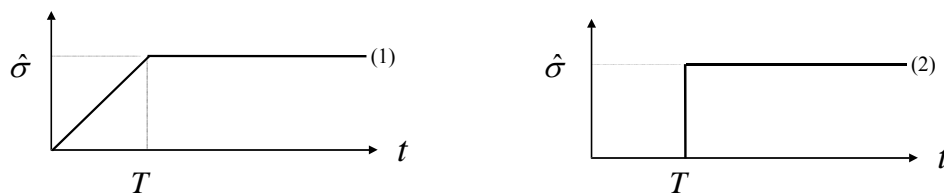

Figure 10.4.5: two stress histories

Examine load (1) first. The stress history is

$$\sigma(t) = \begin{cases} \frac{\hat{\sigma}}{T}t, & t < T \\ \hat{\sigma}, & t > T \end{cases}$$

In the hereditary integral 10.4.20, the creep compliance function $J(t)$ is given by 10.3.8, $J(t) = t/\eta + 1/E$, and the stress is zero at time zero, so $\sigma(0) = 0$. The strain is then

$$0 < t < T : d\sigma/dt = \hat{\sigma}/T$$

$$\varepsilon(t) = \sigma(0)J(t) + \int_0^t J(t-\tau) \frac{d\sigma(\tau)}{d\tau} d\tau = \frac{\hat{\sigma}}{T} \int_0^t \left[\frac{t-\tau}{\eta} + \frac{1}{E} \right] d\tau = \frac{\hat{\sigma}}{T} \left[\frac{t^2}{2\eta} + \frac{t}{E} \right]$$

$$T < t : d\sigma/dt = 0$$

$$\begin{aligned} \varepsilon(t) &= \sigma(0)J(t) + \int_0^T J(t-\tau) \frac{d\sigma(\tau)}{d\tau} d\tau + \int_T^t J(t-\tau) \frac{d\sigma(\tau)}{d\tau} d\tau \\ &= \int_0^T J(t-\tau) \frac{d\sigma(\tau)}{d\tau} d\tau = \frac{\hat{\sigma}}{T} \int_0^T \left[\frac{t-\tau}{\eta} + \frac{1}{E} \right] d\tau = \hat{\sigma} \left[\frac{t-T/2}{\eta} + \frac{1}{E} \right] \end{aligned}$$

For load history (2),

$$\sigma(t) = \begin{cases} 0, & t < T \\ \hat{\sigma}, & t > T \end{cases}$$

The strain is then $\varepsilon(t) = 0$ for $t < T$. The hereditary integral 10.4.20 allows for a jump at $t = 0$. For a jump from zero stress to a non-zero stress at $t = T$ it can be modified to

$$\varepsilon(t) = \sigma(T)J(t-T) = \hat{\sigma} \left[\frac{t-T}{\eta} + \frac{1}{E} \right]$$

which is less than the strain due to load (1). (Alternatively, one could use the Heaviside step function and let $\sigma(t) = \hat{\sigma}H(t-T)$ in 10.4.20, leading to the same result,

$$\varepsilon(t) = \sigma(0)J(t) + \hat{\sigma} \int_0^t J(t-\tau) \delta(\tau-T) d\tau = \hat{\sigma}J(t-T) .)$$

This example illustrates two points:

- (1) the material has a "memory". It remembers the previous loading history, responding differently to different loading histories
- (2) the rate of loading is important in viscoelastic materials. This result agrees with an observed phenomenon: the strain in viscoelastic materials is larger for stresses which grow gradually to their final value, rather than when applied more quickly⁴.

⁴ for the Maxwell model, if one applied the second load at time $t = T/2$, so that the total stress applied in (1) and (2) was the same, one would have obtained the same response after time T , but this is not the case in general

10.4.3 Non-linear Hereditary Integrals

The linear viscoelastic models can be extended into the non-linear range in a number of ways. For example, generalising expressions of the form 10.4.14,

$$\sigma(t) = f_1(\varepsilon(t)) + \int_0^t R(t-\tau) f_2(\varepsilon(t)) d\tau \quad (10.4.22)$$

where f_1, f_2 are non-linear functions of the strain history. The relaxation function can also be assumed to be a function of strain as well as time:

$$\sigma(t) = f_1(\varepsilon(t)) + \int_0^t K(t-\tau, \varepsilon) f_2(\varepsilon(t)) d\tau \quad (10.4.23)$$

10.4.4 Problems

1. Derive the hereditary integral 10.4.21,

$$\sigma(t) = \varepsilon(0)E(t) + \int_0^t E(t-\tau) \frac{d\varepsilon(\tau)}{d\tau} d\tau$$

2. Use the hereditary integral form of the constitutive equation for a linear viscoelastic material, Eqn. 10.4.20, to evaluate the response of a material with creep compliance function

$$J(t) = \ln(t+1)$$

to a load $\sigma(t) = \sigma_0(1+Bt)$. Sketch $J(t)$, which of course gives the strain response due to a unit load $\sigma(t) = 1$. Sketch also the load $\sigma(t)$ and the calculated strain $\varepsilon(t)$.

[note: $\int_0^t \ln[(b-x)+1] dx = -(b-t+1)\ln(b-t+1) + (b+1)\ln(b+1) - t$]

3. A creep test was carried out on a certain linear viscoelastic material and the data was fitted approximately by the function

$$\varepsilon(t) = \hat{\sigma}(1 - e^{-2t}),$$

where $\hat{\sigma}$ was the constant applied load.

- (i) Sketch this strain response over $0 \leq t \leq 3$ (very roughly, with $\hat{\sigma} = 1$).
- (ii) Which of the following three rheological models could be used to model the material:
 - (a) the full generalized Kelvin chain of Fig. 10.3.9
 - (b) the Kelvin chain minus the free spring
 - (c) the generalized Maxwell model minus the free spring and free dash-pot
 Give reasons for your choice (and reasons for discounting the other two).
- (iii) For the rheological model you chose in part (ii), roughly sketch the response to a standard creep-recovery test (the response during the loading phase has already been done in part (i)).
- (iv) Find the material's response to a load $\sigma(t) = t^2 + 1$.

4. Determine the strain response of the Kelvin model to a stress history which is triangular in time:

$$\sigma(t) = \begin{cases} \sigma(t) = 0, & t < 0 \\ \sigma(t) = (\sigma_c / t_1)t, & 0 < t < t_1 \\ \sigma(t) = 2\sigma_c - (\sigma_c / t_1)t, & t_1 < t < 2t_1 \\ \sigma(t) = 0, & 2t_1 < t < \infty \end{cases}$$

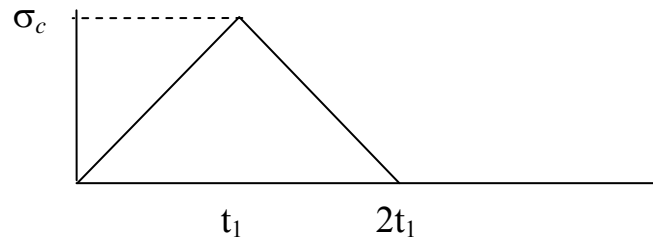

10.4.5 Appendix to §10.4

1. The Heaviside Step Function and the Dirac Delta Functions

The **Heaviside step function** $H(t)$ is defined through

$$H(t-a) = \begin{cases} 0, & t < a \\ 1/2, & t = a \\ 1, & t > a \end{cases} \quad (10.4.24)$$

and is illustrated in Fig. 10.4.6a. The derivative of the Heaviside step function, dH/dt , can be evaluated by considering $H(t-a)$ to be the limit of the function $f(t)$ shown in Fig. 10.4.6b as $\mathcal{G} \rightarrow 0$. This derivative df/dt is shown in Fig. 10.4.6c and in the limit is

$$\frac{dH(t-a)}{dt} = \lim_{\mathcal{G} \rightarrow 0} \frac{df}{dt} = \delta(t-a) \quad (10.4.25)$$

where δ is the **Dirac delta function** defined through (the integral here states that the “area” is unity, as illustrated in Fig. 10.4.6c)

$$\delta(t-a) = \begin{cases} \infty, & t = a \\ 0 & \text{otherwise} \end{cases}, \quad \int_{-\infty}^{+\infty} \delta(t-a) dt = 1 \quad (10.4.26)$$

Integrals involving delta functions are evaluated as follows: consider the integral

$$\int_{-\infty}^{+\infty} g(t)\delta(t-b)dt \quad (10.4.27)$$

The delta function here is zero, and hence the integrand is zero, everywhere except at $t = b$. Thus the integral is

$$\int_{-\infty}^{+\infty} g(t)\delta(t-b)dt = \int_{-\infty}^{+\infty} g(b)\delta(t-b)dt = g(b) \int_{-\infty}^{+\infty} \delta(t-b)dt = g(b) \quad (10.4.28)$$

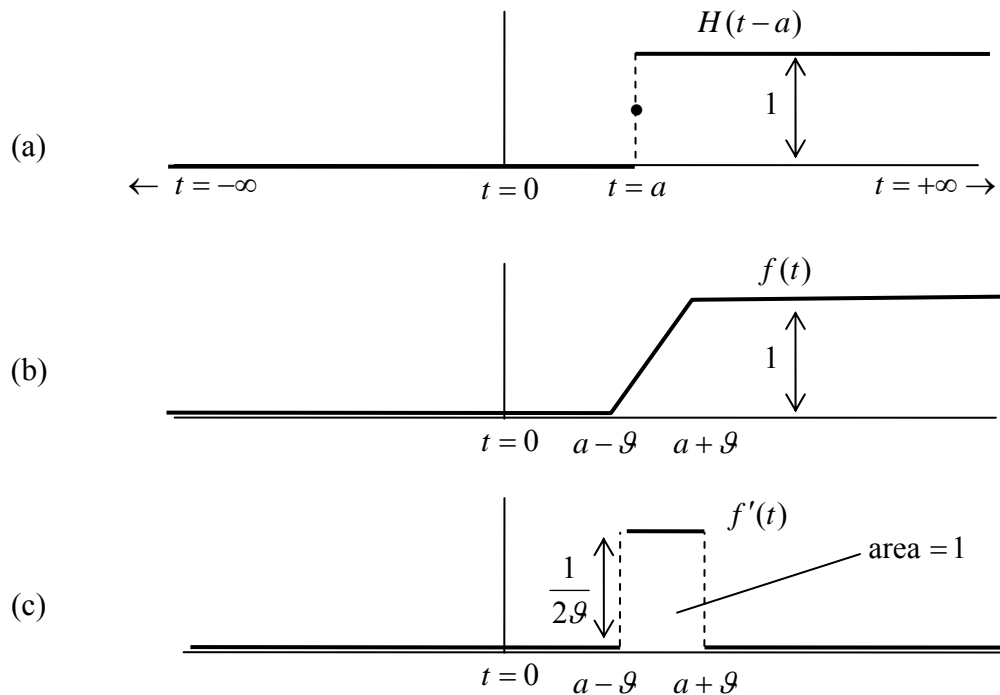

Figure 10.4.6: The Heaviside Step Function and evaluation of its derivative

2. The Maxwell Model: Functions of the Stress

In §10.4.1, the hereditary integrals for the Maxwell model were derived for the stress in terms of integrals of the strain. Here, they are derived for the strain in terms of integrals of the stress.

Consider again the differential equation for the Maxwell model, Eqn. 7.3.6,

$$\frac{d\varepsilon}{dt} = \frac{1}{E} \frac{d\sigma}{dt} + \frac{1}{\eta} \sigma \quad (10.4.29)$$

Direct integration gives

$$\varepsilon(t) = \frac{1}{E} \sigma(t) + \int_{-\infty}^t \frac{1}{\eta} \sigma(\tau) d\tau \quad (10.4.30)$$

Integrating by parts leads to

$$\varepsilon(t) = \left(\frac{1}{E} + \frac{t}{\eta} \right) \sigma(t) - \int_{-\infty}^t \frac{\tau}{\eta} \frac{d\sigma(\tau)}{d\tau} d\tau \quad (10.4.31)$$

Bringing the first term inside the integral,

$$\varepsilon(t) = \int_{-\infty}^t \left(\frac{1}{E} + \frac{t-\tau}{\eta} \right) \frac{d\sigma(\tau)}{d\tau} d\tau \quad (10.4.32)$$

or

$$\varepsilon(t) = \int_{-\infty}^t J(t-\tau) \frac{d\sigma(\tau)}{d\tau} d\tau \quad (10.4.33)$$

where the creep function is $J(t) = 1/E + t/\eta$.

If there is a jump in stress at $t = 0$, 10.4.33 can be expressed as an integral over $[0, t]$ by evaluating the contribution of the jump to the integral in 10.4.33:

$$\begin{aligned} \lim_{g \rightarrow 0} \int_{-g}^{+g} \left[\frac{1}{E} + \frac{t-\tau}{\eta} \right] \frac{\sigma(0)}{2g} d\tau &= \lim_{g \rightarrow 0} \frac{\sigma(0)}{2g} \left[\frac{1}{E} \tau + \frac{t\tau - \tau^2/2}{\eta} \right]_{-g}^{+g} = \lim_{g \rightarrow 0} \frac{\sigma(0)}{2g} 2g \left(\frac{1}{E} + \frac{t}{\eta} \right) \\ &= \left(\frac{1}{E} + \frac{t}{\eta} \right) \sigma(0) \end{aligned} \quad (10.4.34)$$

leading to

$$\varepsilon(t) = J(t)\sigma(0) + \int_0^t J(t-\tau) \frac{d\sigma(\tau)}{d\tau} d\tau \quad (10.4.35)$$

Alternatively, one could also have simply let $\sigma(t) \rightarrow H(t)\sigma(t)$ in 10.4.33, again leading to the term $\int_{-\infty}^t J(t-\tau)\sigma(\tau)\delta(\tau)d\tau = J(t)\sigma(0)$.

Finally, integrating by parts, one also has

$$\varepsilon(t) = J(0)\sigma(t) - \int_0^t S(t-\tau)\sigma(\tau)d\tau \quad (10.4.36)$$

where $S(t) = -dJ(t)/dt$.

3. The Kelvin Model: Functions of the Stress

Consider the differential equation for the Kelvin model, Eqn. 10.3.11,

$$\frac{d\varepsilon}{dt} + \frac{E}{\eta} \varepsilon = \frac{1}{\eta} \sigma \quad (10.4.37)$$

Using the integrating factor $e^{Et/\eta}$, one has

$$\frac{d}{dt} (e^{Et/\eta} \varepsilon(t)) = \frac{1}{\eta} e^{Et/\eta} \sigma(t) \quad (10.4.38)$$

Integrating both sides over $[-\infty, \hat{t}]$ gives

$$(e^{Et/\eta} \varepsilon)_i - (e^{Et/\eta} \varepsilon)_{-\infty} = \int_{-\infty}^{\hat{t}} \frac{1}{\eta} e^{Et/\eta} \sigma(t) dt \quad (10.4.39)$$

or

$$\varepsilon(\hat{t}) = \int_{-\infty}^{\hat{t}} \frac{1}{\eta} e^{-E(\hat{t}-t)/\eta} \sigma(t) dt \quad (10.4.40)$$

Changing the notation,

$$\varepsilon(t) = \int_{-\infty}^t \frac{1}{\eta} e^{-E(t-\tau)/\eta} \sigma(\tau) d\tau \quad (10.4.41)$$

An integration by parts leads to

$$\varepsilon(t) = \frac{1}{E} \sigma(t) - \int_{-\infty}^t \frac{1}{E} e^{-E(t-\tau)/\eta} \frac{d\sigma(\tau)}{d\tau} d\tau \quad (10.4.42)$$

Finally, taking the free term inside the integral:

$$\varepsilon(t) = \int_{-\infty}^t J(t-\tau) \frac{d\sigma(\tau)}{d\tau} d\tau \quad (10.4.43)$$

where $J(t) = (1 - e^{-Et/\eta})/E$ is the creep compliance function for the Kelvin model.

The other versions of the hereditary integral, Eqn. 10.4.10, 10.4.14 can be derived from this as before.

10.5 Linear Viscoelasticity and the Laplace Transform

The Laplace transform is very useful in constructing and analysing linear viscoelastic models.

10.5.1 The Laplace Transform

The formula for the Laplace transform of the derivative of a function is¹:

$$\begin{aligned} L(\dot{f}) &= s\bar{f} - f(0) \\ L(\ddot{f}) &= s^2\bar{f} - sf(0) - \dot{f}(0), \quad \text{etc.} \end{aligned} \quad (10.5.1)$$

where s is the transform variable, the overbar denotes the Laplace transform of the function, and $f(0)$ is the value of the function at time $t = 0$. The Laplace transform is defined in such a way that $f(0)$ refers to $t = 0^-$, that is, just before time zero. Some other important Laplace transforms are summarised in Table 10.5.1, in which α is a constant.

$f(t)$	$\bar{f}(s)$
α	α/s
$H(t)$	$1/s$
$\delta(t - \tau)$	$e^{-s\tau}$
$\dot{\delta}(t)$	s
$e^{-\alpha t}$	$1/(\alpha + s)$
$(1 - e^{-\alpha t})/\alpha$	$1/s(\alpha + s)$
$t/\alpha - (1 - e^{-\alpha t})/\alpha^2$	$1/s^2(\alpha + s)$
t^n	$n!/s^{1+n}, \quad n = 0, 1, \dots$

Table 10.5.1: Laplace Transforms

Another useful formula is the time-shifting formula:

$$L[f(t - \tau)H(t - \tau)] = e^{-s\tau}\bar{f}(s) \quad (10.5.2)$$

10.5.2 Mechanical models revisited

The Maxwell Model

The Maxwell model is governed by the set of three equations 10.3.5:

¹ this rule actually only works for functions whose derivatives are continuous, although the derivative of the function being transformed may be piecewise continuous. Discontinuities in the function or its derivatives introduce additional terms

$$\varepsilon_1 = \frac{1}{E}\sigma, \quad \dot{\varepsilon}_2 = \frac{1}{\eta}\sigma, \quad \varepsilon = \varepsilon_1 + \varepsilon_2 \quad (10.5.3)$$

Taking Laplace transforms gives

$$\bar{\varepsilon}_1 = \frac{1}{E}\bar{\sigma}, \quad s\bar{\varepsilon}_2 = \frac{1}{\eta}\bar{\sigma}, \quad \bar{\varepsilon} = \bar{\varepsilon}_1 + \bar{\varepsilon}_2 \quad (10.5.4)$$

and it has been assumed that the strain ε_2 is zero at $t = 0^-$. The three differential equations have been reduced to a set of three algebraic equations, which may now be solved to get

$$\bar{\sigma} + \frac{\eta}{E}s\bar{\sigma} = \eta s\bar{\varepsilon} \quad (10.5.5)$$

Transforming back then gives Eqn. 10.3.6:

$$\sigma + \frac{\eta}{E}\dot{\sigma} = \eta\dot{\varepsilon} \quad (10.5.6)$$

Now examine the response to a sudden load. When using the Laplace transform, the load is written as $\sigma(t) = \sigma_o H(t)$, where $H(t)$ is the Heaviside step function (see the Appendix to the previous section). Then 10.5.6 reads

$$\sigma_o H(t) + \frac{\eta}{E}\sigma_o \delta(t) = \eta\dot{\varepsilon} \quad (10.5.7)$$

Using the Laplace transform gives

$$\frac{\sigma_o}{s} + \frac{\eta}{E}\sigma_o = \eta s\bar{\varepsilon} \quad \rightarrow \quad \bar{\varepsilon} = \frac{\sigma_o}{E} \frac{1}{s} + \frac{\sigma_o}{\eta} \frac{1}{s^2} \quad \rightarrow \quad \varepsilon(t) = \frac{\sigma_o}{E} H(t) + \frac{\sigma_o}{\eta} t \quad (10.5.8)$$

which is the same result as before, Eqn. 10.3.7-8. Subsequent unloading, at time $t = \tau$ say, can be dealt with most conveniently by superimposing another load $\sigma(t) = -\sigma_o H(t - \tau)$ onto the first. Putting this into the constitutive equation and using the Laplace transform gives

$$\bar{\varepsilon} = -\frac{\sigma_o}{\eta} \frac{1}{s^2} e^{-s\tau} - \frac{\sigma_o}{E} \frac{1}{s} e^{-s\tau} \quad (10.5.9)$$

Transforming back, again using the time-shifting rule, gives

$$\varepsilon(t) = -\frac{\sigma_o}{\eta} (t - \tau) H(t - \tau) - \frac{\sigma_o}{E} H(t - \tau) \quad (10.5.10)$$

Adding this to the strain due to the first load then gives the expected result

$$\varepsilon(t) = \begin{cases} \frac{\sigma_o}{E} + \frac{\sigma_o}{\eta} t, & 0 < t < \tau \\ \frac{\sigma_o}{\eta} \tau, & \tau < t \end{cases} \quad (10.5.11)$$

The Kelvin Model

Taking Laplace transforms of the three equations for the Kelvin model, Eqns. 10.3.10, gives $\bar{\sigma} = E\bar{\varepsilon} + \eta s\bar{\varepsilon}$, which yields 10.3.11, $\sigma = E\varepsilon + \eta\dot{\varepsilon}$. The response to a load

$\sigma(t) = \sigma_o H(t)$ is

$$\sigma_o H(t) = E\varepsilon + \eta\dot{\varepsilon} \rightarrow \bar{\varepsilon} = \frac{\sigma_o}{\eta} \frac{1}{s(E/\eta + s)} \rightarrow \varepsilon(t) = \frac{\sigma_o}{E} (1 - e^{-(E/\eta)t}) \quad (10.5.12)$$

The response to another load of magnitude $\sigma(t) = -\sigma_o H(t - \tau)$ is

$$\begin{aligned} -\sigma_o H(t - \tau) = E\varepsilon + \eta\dot{\varepsilon} &\rightarrow \bar{\varepsilon} = -\frac{\sigma_o}{\eta} \frac{e^{-s\tau}}{s(E/\eta + s)} \\ &\rightarrow \varepsilon(t) = -\frac{\sigma_o}{E} (1 - e^{-(E/\eta)(t-\tau)}) H(t - \tau) \end{aligned} \quad (10.5.13)$$

The response to both loads now gives the complete creep and recovery response:

$$\varepsilon(t) = \begin{cases} \frac{\sigma_o}{E} (1 - e^{-(E/\eta)t}), & 0 < t < \tau \\ \frac{\sigma_o}{E} e^{-(E/\eta)t} (e^{(E/\eta)\tau} - 1), & t > \tau \end{cases} \quad (10.5.14)$$

To analyse the response to a suddenly applied strain, substitute $\varepsilon(t) = \varepsilon_o H(t)$ into the constitutive equation $\sigma = E\varepsilon + \eta\dot{\varepsilon}$ to get $\sigma = E\varepsilon_o H(t) + \eta\varepsilon_o \delta(t)$, which shows that the relaxation modulus of the Kelvin model is

$$E(t) = E + \eta\delta(t) \quad (10.5.15)$$

The Standard Linear Model

Consider next the standard linear model, which consists of a spring in series with a Kelvin unit, Fig. 10.5.1 (see Fig. 10.3.8a). Upon loading one expects the left-hand spring to stretch immediately. The dash pot then takes up the stress, transferring the load to the second spring as it slowly opens over time. Upon unloading one expects the left-hand spring to contract immediately and for the right-hand spring to slowly contract, being held back by the dash-pot.

The equations for this model are, from the figure,

$$\begin{aligned}
 \sigma &= \sigma_1 + \sigma_2 \\
 \varepsilon &= \varepsilon_1 + \varepsilon_2 \\
 \sigma &= E_1 \varepsilon_1 \\
 \sigma_1 &= E_2 \varepsilon_2 \\
 \sigma_2 &= \eta \dot{\varepsilon}_2
 \end{aligned}
 \tag{10.5.16}$$

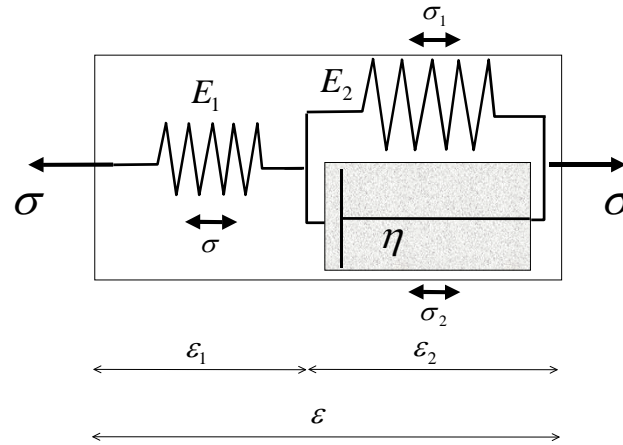

Figure 10.5.1: the standard linear model

One can eliminate the four unknowns from these five equations using the Laplace transform, giving

$$(E_1 + E_2)\bar{\sigma} + \eta s \bar{\sigma} = E_1 E_2 \bar{\varepsilon} + E_1 \eta s \bar{\varepsilon} \tag{10.5.17}$$

which transforms back to (in standard form)

$$\sigma + \frac{\eta}{E_1 + E_2} \dot{\sigma} = \frac{E_1 E_2}{E_1 + E_2} \varepsilon + \frac{E_1 \eta}{E_1 + E_2} \dot{\varepsilon} \tag{10.5.18}$$

which is Eqn. 10.3.16a.

The response to a load $\sigma(t) = \sigma_o H(t)$ is

$$\begin{aligned}
 (E_1 + E_2)\sigma_o H(t) + \eta \sigma_o \delta(t) &= E_1 E_2 \varepsilon + E_1 \eta \dot{\varepsilon} \\
 \rightarrow \bar{\varepsilon} &= \frac{\sigma_o}{E_1} \frac{1}{((E_2/\eta) + s)} + \frac{\sigma_o (E_1 + E_2)}{E_1 \eta} \frac{1}{s((E_2/\eta) + s)} \\
 \rightarrow \varepsilon(t) &= \sigma_o J(t)
 \end{aligned}
 \tag{10.5.19}$$

and the creep compliance is

$$\begin{aligned}
 J(t) &= \frac{1}{E_1} e^{-(E_2/\eta)t} + \frac{E_1 + E_2}{E_1 E_2} (1 - e^{-(E_2/\eta)t}) \\
 &= \frac{1}{E_1} + \frac{1}{E_2} (1 - e^{-(E_2/\eta)t})
 \end{aligned}
 \tag{10.5.20}$$

Note that $\varepsilon(0) = \sigma_o / E_1$ as expected.

For recovery one can superimpose an opposite load onto the first, at time τ say:

$$\begin{aligned}
 -(E_1 + E_2)\sigma_o H(t - \tau) - \eta\sigma_o \delta(t - \tau) &= E_1 E_2 \varepsilon + E_1 \eta \dot{\varepsilon} \\
 \rightarrow \bar{\varepsilon} &= -\frac{\sigma_o}{E_1} \frac{1}{(E_2/\eta + s)} e^{-s\tau} - \sigma_o \left(\frac{E_1 + E_2}{E_1 \eta} \right) \frac{1}{s(E_2/\eta + s)} e^{-s\tau} \\
 \rightarrow \varepsilon(t) &= -\sigma_o H(t - \tau) \left\{ \frac{1}{E_1} e^{-(E_2/\eta)(t-\tau)} + \left(\frac{E_1 + E_2}{E_1 E_2} \right) (1 - e^{-(E_2/\eta)(t-\tau)}) \right\}
 \end{aligned}
 \tag{10.5.21}$$

The response after time τ is then

$$\varepsilon(t) = \frac{\sigma_o}{E_2} e^{-(E_2/\eta)t} (e^{(E_2/\eta)\tau} - 1)
 \tag{10.5.22}$$

This is, as expected, simply the recovery response of the Kelvin unit. The full response is as shown in Fig. 10.5.2. This seems to be fairly close now to the response of a real material as discussed in §10.1, although it does not allow for a permanent strain.

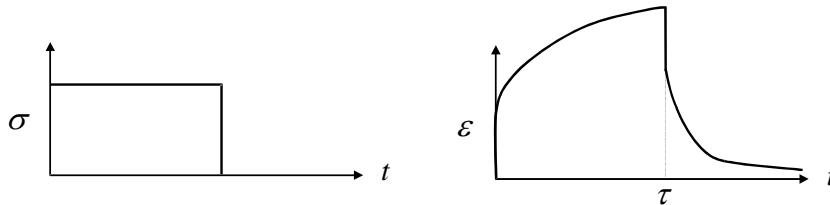

Figure 10.5.2: Creep-recovery response of the standard linear model

Non-constant Loading

The response to a complex loading history can be evaluated by solving the differential constitutive equation (or the corresponding hereditary integral). The differential equation can be most easily solved using Laplace transforms.

Example

Consider the example treated earlier using hereditary integrals, at the end of §10.4.2. Load (1) of Fig. 10.4.5 can be thought of as consisting of the two loads (1a) $\sigma = (\hat{\sigma}/T)t$ and (1b) $\sigma = -(\hat{\sigma}/T)(t-T)H(t-T)$ applied at time $t = T$. Load (2) consists of a constant load applied at time $t = T$.

For load (1a),

$$\frac{\hat{\sigma}}{T}t + \frac{\eta}{E} \frac{\hat{\sigma}}{T} = \eta \dot{\varepsilon} \quad \rightarrow \quad \bar{\varepsilon} = \frac{\hat{\sigma}}{\eta T} \frac{1}{s^3} + \frac{1}{E} \frac{\hat{\sigma}}{T} \frac{1}{s^2} \quad \rightarrow \quad \frac{\varepsilon(t)}{\hat{\sigma}} = \frac{1}{ET}t + \frac{1}{2\eta T}t^2$$

which gives the response for $t < T$.

For load (1b) one has [note: $L((t-\tau)\delta(t-\tau)) = 0$]

$$\begin{aligned} \eta \dot{\varepsilon} &= -\frac{\hat{\sigma}}{T}(t-T)H(t-T) - \frac{\eta}{E} \frac{\hat{\sigma}}{\tau} [(t-T)\delta(t-T) + H(t-T)] \\ \rightarrow s\bar{\varepsilon} &= -\frac{\hat{\sigma}}{\eta T} e^{-Ts} \frac{1}{s^2} - \frac{1}{E} \frac{\hat{\sigma}}{T} e^{-Ts} \frac{1}{s} \\ \rightarrow \bar{\varepsilon} &= -\frac{\hat{\sigma}}{\eta \tau} e^{-Ts} \frac{1}{s^3} - \frac{1}{E} \frac{\hat{\sigma}}{\tau} e^{-Ts} \frac{1}{s^2} \\ \rightarrow \frac{\varepsilon(t)}{\hat{\sigma}} &= H(t-T) \left\{ -\frac{1}{2\eta T} (t-T)^2 - \frac{1}{E\tau} (t-T) \right\} \end{aligned}$$

The response after time T is then given by adding the two results:

$$\frac{\varepsilon(t)}{\hat{\sigma}} = \frac{1}{E} + \frac{1}{\eta} \left(t - \frac{T}{2} \right)$$

10.5.3 Relationship between Creep and Relaxation

Taking the Laplace transform of the general constitutive equation 10.3.19, $\mathbf{P}\sigma = \mathbf{Q}\varepsilon$, leads to

$$\left(p_0 + p_1s + p_2s^2 + p_3s^3 + p_4s^4 + \dots \right) \bar{\sigma} = \left(q_0 + q_1s + q_2s^2 + q_3s^3 + q_4s^4 + \dots \right) \bar{\varepsilon} \quad (10.5.23)$$

which can also be written in the contracted form

$$P(s)\bar{\sigma} = Q(s)\bar{\varepsilon} \quad (10.5.24)$$

where P and Q are the polynomials

$$P(s) = \sum_{i=0}^n p_i s^i, \quad Q(s) = \sum_{i=0}^n q_i s^i \quad (10.5.25)$$

The Laplace transforms of the creep compliance ($J(t) \rightarrow \bar{J}(s)$) and relaxation modulus ($E(t) \rightarrow \bar{E}(s)$) can be written in terms of these polynomials as follows. First, the strain due to a unit load $\sigma = H(t)$ is $J(t)$. Since $\bar{\sigma} = 1/s$, substitution into the above equation gives

$$\bar{J}(s) = \frac{P(s)}{sQ(s)} \quad (10.5.26)$$

Similarly, the stress due to a unit strain $\varepsilon = H(t)$ is $E(t)$ and so

$$\bar{E}(s) = \frac{Q(s)}{sP(s)} \quad (10.5.27)$$

It follows that

$$\boxed{\bar{J}(s)\bar{E}(s) = \frac{1}{s^2}} \quad (10.5.28)$$

Thus, for a linear viscoelastic material, there is a unique and simple relationship between the creep and relaxation behaviour.

10.5.4 Problems

1. Check that the relation 10.5.28, $\bar{J}(s)\bar{E}(s) = 1/s^2$, holds for the Kelvin model
2. (a) Derive the constitutive relation (in standard form) for the three-element model shown below using the Laplace transform (this is the Standard Fluid II of Fig. 10.3.8d and the constitutive relation is given by Eqn. 10.3.16d)
 (b) Derive the creep compliance $J(t)$ by considering a suddenly applied load.

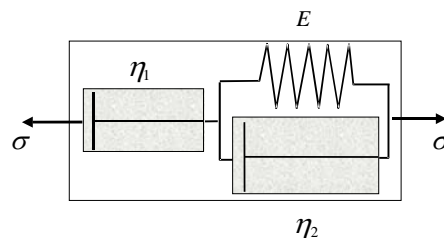

10.6 Oscillatory Stress, Dynamic Loading and Vibrations

Creep and relaxation experiments do not provide complete information concerning the mechanical behaviour of viscoelastic materials. These experiments usually provide test data in the time-range from 10 seconds to 10 years. It is often of interest to know the response of materials to loads of very short duration. For example, duration of the impact of a steel ball on a viscoelastic block may be of the order of 10^{-5} sec^1 . In order to be able to determine the response for such conditions, it is necessary to know the behaviour of a material at high rates of loading (or short duration loading).

The techniques and apparatus for investigating the response of a material to very short term loading are different to those involved in longer-term testing. For very short time loading it is more convenient to use oscillatory than static loading, and in order to predict the behaviour of a viscoelastic material subjected to an oscillatory load, one needs to formulate the theory based on oscillatory stresses and strains.

10.6.1 Oscillatory Stress

Consider a dynamic load of the form

$$\sigma(t) = \sigma_o \cos(\omega t) \quad (10.6.1)$$

where σ_o is the stress amplitude and ω is the angular frequency². Assume that the resulting strain is of the form³

$$\varepsilon(t) = \varepsilon_o \cos(\omega t - \delta) \quad (10.6.2)$$

so that the strain is an oscillation at the same frequency as the stress but lags behind by a phase angle δ , Fig. 10.6.1. This angle is referred to as the **loss angle** of the material, for reasons which will become clear later.

Expanding the strain trigonometric terms,

$$\varepsilon(t) = \varepsilon_o \cos \delta \cos \omega t + \varepsilon_o \sin \delta \sin \omega t \quad (10.6.3)$$

The first term here is completely in phase with the input; the second term is completely out of phase with the input. If the phase angle δ is zero, then the stress and strain are in

¹ dynamic experiments usually provide data from about 10^{-8} sec. to about 10^3 sec. so there is a somewhat overlapping region where data can be obtained from both types of experiment

² when an oscillatory force is first applied, transient vibrations result at the natural frequency of the material – these soon die out leaving the vibrations at the source frequency

³ if one substitutes 10.6.1 into the general constitutive equation 10.3.17, one sees that the strain and its derivatives contain sine and cosine terms, so that the strain must be of the general form

$A \cos(\omega t) + B \sin(\omega t)$, where A and B are constants. For convenience, this can be written as $C \cos(\omega t - D)$ where C and D are new constants

phase (as happens with an ideal elastic material), whereas if $\delta = \pi/2$, the stress and strain are completely out of phase.

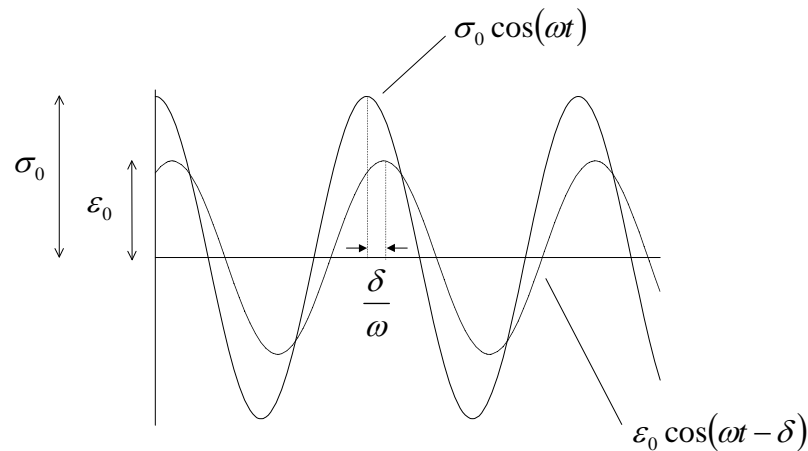

Figure 10.6.1: Oscillatory stress and strain

The Complex Compliance

Define

$$J_1 = \frac{\epsilon_o}{\sigma_o} \cos \delta, \quad J_2 = \frac{\epsilon_o}{\sigma_o} \sin \delta \quad (10.6.4)$$

so that

$$\epsilon(t) = \sigma_o (J_1 \cos \omega t + J_2 \sin \omega t) \quad (10.6.5)$$

The quantities J_1 and J_2 are a measure of how in, or out of, phase the stress is with the strain. The former, J_1 , is called the **storage compliance** and the latter, J_2 , is called the **loss compliance**. They are usually written as the components of a **complex compliance**, J^* :

$$J^* = J_1 - iJ_2 \quad (10.6.6)$$

If one has a stress input in the form of a sine function, then

$$\begin{aligned} \sigma(t) &= \sigma_o \sin(\omega t) \\ \epsilon(t) &= \epsilon_o \sin(\omega t - \delta) \\ &= \epsilon_o \cos \delta \sin \omega t - \epsilon_o \sin \delta \cos \omega t \\ &= \sigma_o (J_1 \sin \omega t - J_2 \cos \omega t) \end{aligned} \quad (10.6.7)$$

and again the storage compliance is a measure of the amount "in phase" and the loss compliance is a measure of the amount "out of phase".

The Complex Modulus

One can also regard of the strain as the input and the stress as the output. In that case one can write (δ is again the phase angle by which the strain lags behind the stress)

$$\begin{aligned}\varepsilon(t) &= \varepsilon_o \cos(\omega t) \\ \sigma(t) &= \sigma_o \cos(\omega t + \delta) \\ &= \sigma_o \cos \delta \cos \omega t - \sigma_o \sin \delta \sin \omega t\end{aligned}\tag{10.6.8}$$

This is in effect the same stress-strain relationship as that used above, only the stress/strain are shifted along the t -axis.

Define next the two new quantities

$$E_1 = \frac{\sigma_o}{\varepsilon_o} \cos \delta, \quad E_2 = \frac{\sigma_o}{\varepsilon_o} \sin \delta\tag{10.6.9}$$

so that

$$\sigma(t) = \varepsilon_o (E_1 \cos \omega t - E_2 \sin \omega t)\tag{10.6.10}$$

Again, these quantities are a measure of how much the response is in phase with the input. The former, E_1 , is called the **storage modulus** and the latter, E_2 , is called the **loss modulus**. As with the compliances, they are usually written as the components of a **complex modulus**⁴, E^* :

$$E^* = E_1 + iE_2\tag{10.6.11}$$

Again, if one has a sinusoidal strain as input, one can write

$$\begin{aligned}\varepsilon(t) &= \varepsilon_o \sin(\omega t) \\ \sigma(t) &= \sigma_o \sin(\omega t + \delta) \\ &= \sigma_o \cos \delta \sin \omega t + \sigma_o \sin \delta \cos \omega t \\ &= \varepsilon_o (E_1 \sin \omega t + E_2 \cos \omega t)\end{aligned}\tag{10.6.12}$$

It is apparent from the above that

$$J^* E^* = 1\tag{10.6.13}$$

which is a much simpler relationship than that between the creep compliance function and the relaxation modulus (which involved Laplace transforms, Eqn. 10.5.28).

⁴ typical values for the storage and loss moduli for a polymer would be around $E_1 = 10$ MPa, $E_2 = 0.1$ MPa. The ratio of the amplitudes is called the **dynamic modulus**, $|E^*| = \sigma_o / \varepsilon_o$.

Complex Formulation

The above equations can be succinctly written using a complex formulation, using Euler's formula

$$e^{\pm i\theta} = \cos \theta \pm i \sin \theta \quad (10.6.14)$$

For a stress input,

$$\begin{aligned} \sigma(t) &= \sigma_o e^{i\omega t} \\ \varepsilon(t) &= \varepsilon_o e^{i(\omega t - \delta)} \\ &= \varepsilon_o (\cos \delta - i \sin \delta) e^{i\omega t} \\ &= \sigma_o [J_1 - iJ_2] e^{i\omega t} \\ &= \sigma_o J^* e^{i\omega t} \end{aligned} \quad (10.6.15)$$

The creep compliance function $J(t)$ is the strain response to a unit load. In the same way, from 10.6.15, the complex compliance J^* can be interpreted as the strain amplitude response to a sinusoidal stress input of unit magnitude.

Similarly, for a strain input, one has

$$\begin{aligned} \varepsilon(t) &= \varepsilon_o e^{i\omega t} \\ \sigma(t) &= \sigma_o e^{i(\omega t + \delta)} \\ &= \sigma_o (\cos \delta + i \sin \delta) e^{i\omega t} \\ &= \varepsilon_o E^* e^{i\omega t} \end{aligned} \quad (10.6.16)$$

and the term in brackets is, by definition, the complex modulus E^* .

The relationship between the complex compliance/modulus and the differential constitutive equation

Putting $\sigma(t) = \sigma_o e^{i\omega t}$ and the resulting strain $\varepsilon(t) = \varepsilon_o e^{(i\omega - \delta)t}$ into the general differential operator form of the constitutive equation 10.3.19, one has

$$\begin{aligned} & [p_o + p_1(i\omega) + p_2(i\omega)^2 + p_3(i\omega)^3 + \dots] \sigma_o e^{i\omega t} \\ &= [q_o + q_1(i\omega) + q_2(i\omega)^2 + q_3(i\omega)^3 + \dots] \sigma_o J^* e^{i\omega t} \end{aligned} \quad (10.6.17)$$

This equation thus gives the relationship between the complex compliance and the constants p_i, q_i . A similar relationship can be found for the complex modulus:

$$E^* = \frac{q_o + q_1(i\omega) + q_2(i\omega)^2 + q_3(i\omega)^3 + \dots}{p_o + p_1(i\omega) + p_2(i\omega)^2 + p_3(i\omega)^3 + \dots} \quad (10.6.18)$$

Again one sees that $J^* E^* = 1$.

From 10.6.17-18, the complex compliance and complex modulus are functions of the frequency ω , and thus, from the definitions 10.6.4, 10.6.6, 10.6.9, 10.6.11, so is the phase angle δ . Thus ω is the primary variable influencing the viscoelastic properties (whereas time t was used for this purpose in the analysis of static loading).

The relationship between the complex compliance/modulus and the creep compliance/ relaxation modulus

It can be shown⁵ that the complex compliance $J^*(\omega)$ and the complex modulus $E^*(\omega)$ are related to the creep compliance $J(t)$ and relaxation modulus $E(t)$ through

$$\begin{aligned} J^*(\omega) &= (i\omega)L[J(t)]_{s=i\omega} \\ E^*(\omega) &= (i\omega)L[E(t)]_{s=i\omega} \end{aligned} \quad (10.6.19)$$

Here, the Laplace transform is first taken and then evaluated at $s = i\omega$ ⁶.

A Note on Frequency

Frequencies below 0.1 Hz are associated with seismic waves. Vibrations of structures and solid objects occur from about 0.1 Hz to 10 kHz depending on the size of the structure. Stress waves from 20 Hz to 20 kHz are perceived as sound - above 20 kHz is the ultrasonic range. Frequencies above 10^{12} Hz correspond to molecular vibration and represent an upper limit for stress waves in real solids.

10.6.2 Example: The Maxwell Model

The constitutive equation for the Maxwell model is given by Eqn. 10.3.6,

$$\sigma + \frac{\eta}{E} \dot{\sigma} = \eta \dot{\varepsilon} \quad (10.6.20)$$

Consider an oscillatory stress $\sigma = \sigma_o \cos(\omega t)$. We thus have⁷

$$\begin{aligned} \sigma_o \cos(\omega t) - \frac{\eta}{E} \omega \sigma_o \sin(\omega t) &= \eta \dot{\varepsilon} \rightarrow \int d\varepsilon = \sigma_o \left\{ -\frac{\omega}{E} \int \sin(\omega t) dt + \frac{1}{\eta} \int \cos(\omega t) dt \right\} \\ \rightarrow \varepsilon(t) &= \sigma_o \left\{ \frac{1}{E} \cos(\omega t) + \frac{1}{\omega \eta} \sin(\omega t) \right\} \end{aligned} \quad (10.6.21)$$

⁵ using Fourier transform theory for example

⁶ J_1 and J_2 are also related to each other (as are E_1 and E_2) by an even more complicated rule known as the **Kramers-Kronig relation**

⁷ the constant of integration is zero (assuming that the initial strain is that in the spring, σ_o / E).

Thus the complex compliance is

$$J^* = J_1 - iJ_2 = \frac{1}{E} - i \frac{1}{\omega\eta} \quad (10.6.22)$$

This result can be obtained more easily using the relationship between the complex compliance and the constitutive equation: the constitutive equation can be rewritten as

$$p_o\sigma + p_1\dot{\sigma} = q_o\varepsilon + q_1\dot{\varepsilon}, \quad \text{where } p_o = 1, p_1 = \frac{\eta}{E}, q_o = 0, q_1 = \eta \quad (10.6.23)$$

From Eqn. 10.6.17,

$$J^* = \frac{p_o + p_1(i\omega) + p_2(i\omega)^2 + \dots}{q_o + q_1(i\omega) + q_2(i\omega)^2 + \dots} = \frac{1 + (\eta/E)(i\omega)}{\eta(i\omega)} = \frac{1}{E} - i \frac{1}{\omega\eta} \quad (10.6.24)$$

Also, the complex modulus is related to the complex compliance through 10.6.13, $E^* = 1/J^*$, so that

$$E^* = \frac{(\omega\eta)^2 E}{(\omega\eta)^2 + E^2} + i \frac{\omega\eta E^2}{(\omega\eta)^2 + E^2} \quad (10.6.25)$$

For very low frequencies, $\omega \rightarrow 0$, $\sin(\omega t)/\omega \rightarrow t$, and the response, as expected, reduces to that for a static load, $\varepsilon(t) = \sigma_o(1/E + t/\eta)$.

For very high frequencies, $1/\omega \rightarrow 0$, and the response is $\varepsilon(t) = (\sigma_o/E)\cos(\omega t)$. Thus the strain is completely in-phase with the load, but the dash-pot is not moving – it has no time to respond at such high frequencies - the spring/dash-pot model is reacting like an isolated spring, that is, like a solid, with no fluid behaviour.

10.6.3 Energy Dissipation

Because the equations 10.6.12

$$\varepsilon(t) = \varepsilon_o \sin(\omega t), \quad \sigma(t) = \sigma_o \sin(\omega t + \delta) \quad (10.6.26)$$

are the parametric equations for an ellipse, that is, they trace out an ellipse for values of t , the stress-strain curve for an oscillatory stress is an elliptic hysteresis loop, Fig. 10.6.2.

The work done in stressing a material (per unit volume) is given by

$$W = \int \sigma d\varepsilon \quad (10.6.27)$$

The energy lost ΔW through internal friction and heat is given by the area of the ellipse. Thus

$$\Delta W = \int_{t_1}^{t_1+T} \sigma d\varepsilon = \int_{t_1}^{t_1+T} \sigma \frac{d\varepsilon}{dt} dt \quad (10.6.28)$$

where t_1 is some starting time and T is the period of oscillation, $T = 2\pi / \omega$. Substituting in Eqns. 10.6.26 for strain and stress then gives

$$\begin{aligned} \Delta W &= \omega \sigma_o \varepsilon_o \int_{t_1}^{t_1+T} \sin(\omega t + \delta) \cos(\omega t) dt \\ &= \frac{1}{2} \omega \sigma_o \varepsilon_o \int_{t_1}^{t_1+T} [\sin(2\omega t + \delta) + \sin \delta] dt \\ &= \frac{1}{2} \omega \sigma_o \varepsilon_o \left[-\frac{\cos(2\omega t + \delta)}{2\omega} + t \sin \delta \right]_{t_1}^{t_1+T} \end{aligned} \quad (10.6.29)$$

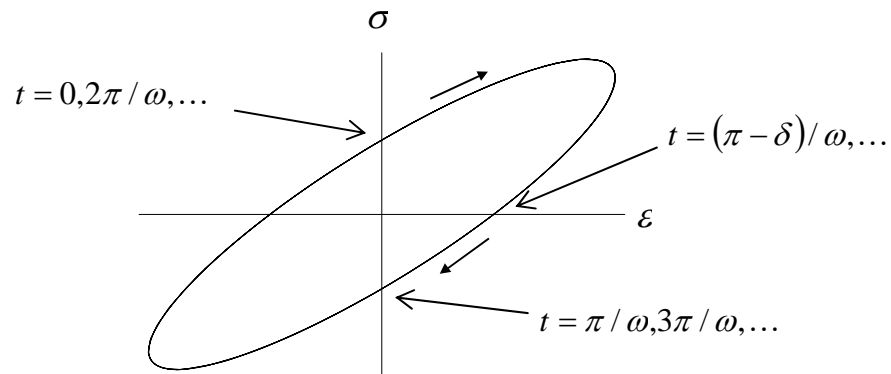

Figure 10.6.2: Elliptic Stress-Strain Hysteresis Loop

Taking $t_1 = 0$ then gives⁸

$$\boxed{\Delta W = \pi \sigma_o \varepsilon_o \sin \delta} \quad \text{Energy Loss} \quad (10.6.30)$$

When $\delta = 0$, the energy dissipated is zero, as in an elastic material. It can also be seen that

$$\Delta W = \pi \varepsilon_o^2 E_2 = \pi \sigma_o^2 J_2 \quad (10.6.31)$$

and hence the names *loss modulus* and *loss compliance*.

⁸ the same result is obtained for $\sigma = \sigma_o \sin(\omega t)$, $\varepsilon = \varepsilon_o \sin(\omega t - \delta)$ or when the stress and strain are cosine functions

Damping Energy

The energy stored after one complete cycle is zero since the material has returned to its original configuration. The maximum energy stored during any one cycle can be computed by integrating the increment of work $\sigma d\epsilon$ from zero up to a maximum stress, that is over one quarter the period T of one cycle. Thus, integrating from $t_1 = -\delta/\omega$ (where $\sigma = 0$) to $t_2 = t_1 + \pi/2\omega$, Fig. 10.6.3⁹

$$W = \sigma_o \epsilon_o \left[\frac{\cos \delta}{2} + \frac{\pi}{4} \sin \delta \right] \quad (10.6.32)$$

The second term is $\pi \sigma_o \epsilon_o \sin \delta / 4$, which is one quarter of the energy dissipated per cycle, and so can be considered to represent the dissipated energy. The remaining, first, term represents the area of the shaded triangle in Fig. 10.6.3 and can be considered to be the energy stored, $W_s = \sigma_o \epsilon_o \cos \delta / 2$ (it reduces to the elastic solution $W = \sigma_o \epsilon_o / 2$ when $\delta = 0$).

The **damping energy** of a viscoelastic material is defined as $\Delta W / W_s$, where W_s is the maximum energy the system can store in a given stress/strain amplitude. Thus (dividing ΔW by 4 so it is consistent with the integration over a quarter-cycle to obtain the stored energy)

$$\boxed{\frac{\Delta W}{W_s} = \frac{\pi}{2} \tan \delta} \quad \text{Damping Energy} \quad (10.6.33)$$

Thus the damping ability of a linearly viscoelastic material is only dependent on the phase/loss angle δ .

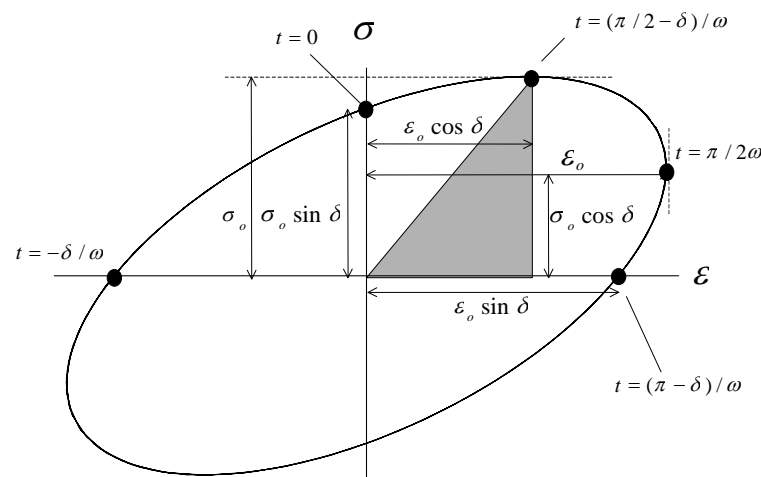

Figure 10.6.3: Elliptic Stress-Strain Hysteresis Loop

⁹ or one could integrate from zero to maximum strain, over $[0, \pi/2\omega]$, giving the same result

The quantity $\tan \delta$ is known as the **mechanical loss**, or the **loss tangent**. It can be considered to be the fundamental measure of damping in a linear material (other measures, for example δ , $2\pi \tan \delta$, etc., are often used)¹⁰. Typical values for a range of materials at various temperatures and frequencies are shown in Table 10.6.1.

Material	Temperature	Frequency (ν)	Loss Tangent ($\tan \delta$)
Sapphire	4.2 K	30 kHz	2.5×10^{-10}
Sapphire	rt	30 kHz	5×10^{-9}
Silicon	rt	20 kHz	3×10^{-8}
Quartz	rt	1 MHz	$\approx 10^{-7}$
Aluminium	rt	20 kHz	$< 10^{-5}$
Cu-31%Zn	rt	6 kHz	9×10^{-5}
Steel	rt	1 Hz	0.0005
Aluminium	rt	1 Hz	0.001
Fe-0.6%V	33°C	0.95 Hz	0.0016
Basalt	rt	0.001-0.5 Hz	0.0017
Granite	rt	0.001-0.5 Hz	0.0031
Glass	rt	1 Hz	0.0043
Wood	rt	≈ 1 Hz	0.02
Bone	37°C	1-100 Hz	0.01
Lead	rt	1-15 Hz	0.029
PMMA	rt	1 Hz	0.1

Table 10.6.1: Loss Tangents of Common Materials¹¹

10.6.4 Impact

Consider the impact of a viscoelastic ball dropped from a height h_d onto a rigid floor. During the impact, a proportion of the initial potential energy mgh_d , which is now kinetic energy $\frac{1}{2}mv^2$, where v is the velocity at impact, is lost and only some is stored. The stored energy is converted back to kinetic energy which drives the ball up on the rebound, reaching a height $h_r < h_d$, with final potential energy mgh_r . The ratio of the two heights is¹²

$$f \equiv \frac{h_r}{h_d} = \frac{mgh_r}{mgh_d} = \frac{W_s}{W_s + W_d} \quad (10.6.34)$$

where W_s is the energy stored and W_d is the energy dissipated during the impact.

¹⁰ some investigators recommend that one uses the maximum storable energy when $\delta = 0$, in which case the stored energy is $\sigma_o \varepsilon_o / 2$ and the damping measure would be $\Delta W / W_s = \pi \sin \delta / 2$

¹¹ from Table 7.1 of Viscoelastic Solids, by R. S. Lakes, CRC Press, 1999

¹² the **coefficient of restitution** e is defined as the ratio of the velocities before and after impact, $e = v_r / v_d$, so $f = e^2$.

The impact event can be approximated by a half-cycle of the oscillatory stress-strain curve, Fig. 10.6.4. Integrating over $[0, \pi/\omega]$ or $[-\delta/\omega, (\pi - \delta)/\omega]$, one has¹³

$$W = \frac{1}{2} \sigma_o \varepsilon_o [\cos \delta + \pi \sin \delta] \quad (10.6.35)$$

and so the “height lost” is given by

$$f = 1 - \frac{W_d}{W_s + W_d} \approx 1 - \frac{W_d}{W_s} = 1 - \pi \tan \delta \quad (10.6.36)$$

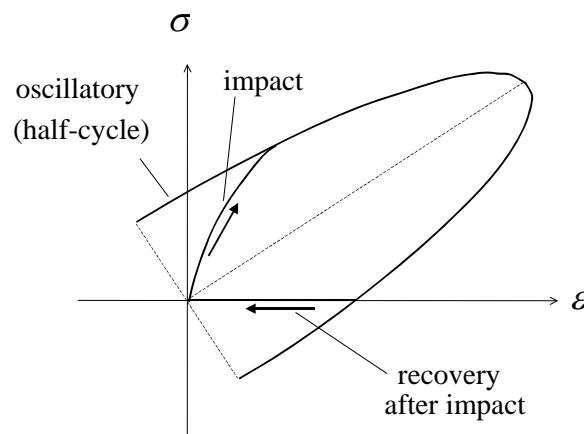

Figure 10.6.4: Impact approximated as a half-cycle of oscillatory stress and strain

Note some other approximations made:

- (i) energy losses due to air resistance, friction and radiation of sound energy during impact have been neglected
- (ii) in a real impact, the stress and strain are both initially zero. In the current analysis, when one of these quantities is zero, the other is finite, and this will inevitably introduce some error¹⁴.

10.6.5 Damping of Vibrations

The inertial force in many applications can be neglected. However, when dealing with vibrations, the product of acceleration times mass can be appreciable when compared to the other forces present.

Vibrational damping can be examined by looking at a simple oscillator with one degree of freedom, Fig. 10.6.5. A mass m is connected to a wall by a viscoelastic bar of length L and cross sectional area A . The motion of the system is described by the equations

¹³ although it might be more accurate to integrate over $[0, (\pi - \delta)/\omega]$

¹⁴ as mentioned, there is a transient term involved in the oscillation which has been ignored, and which dies out over time, leaving the strain to lag behind the stress at a constant phase angle

Dynamic equation: $m\ddot{x} + F = 0$
 Kinematic relation: $\varepsilon = x/L$
 Constitutive relation: (depends on model)

Assuming an oscillatory motion, $x = x_o e^{i\omega t}$, and using the first two of these,

$$-\omega^2 m x_o e^{i\omega t} + A\sigma = 0 \quad \rightarrow \quad \sigma = \frac{x_o}{L} \frac{L\omega^2 m}{A} e^{i\omega t} = \varepsilon_o \left[\frac{L\omega^2 m}{A} \right] e^{i\omega t} \quad (10.6.37)$$

The quantity in brackets is the complex modulus E^* (see Eqn. 10.6.16).

As an example, for the Maxwell model (see Eqn. 10.6.24)

$$E^* = \left[\frac{1}{E} - \frac{i}{\eta\omega} \right]^{-1} \quad (10.6.38)$$

and so

$$\frac{1}{E} \omega^2 - \frac{i}{\eta} \omega = \frac{A}{Lm}, \quad (10.6.39)$$

which can be solved to get

$$\omega = \left\{ \frac{E}{2\eta} i \pm \sqrt{\frac{AE}{Lm} - \frac{E^2}{4\eta^2}} \right\} \quad (10.6.40)$$

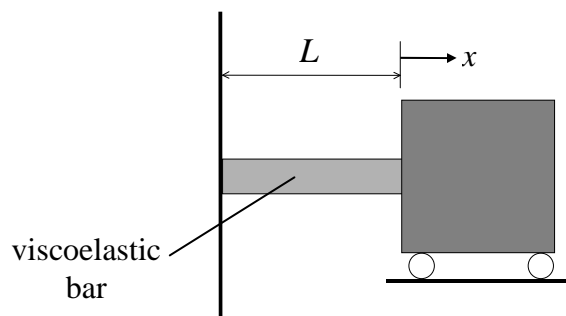

Figure10.6.5: Vibration

If m is small or E is large (and E/η is not too large) the root has a real part, ν say, so that

$$\omega = i(E/2\eta) \pm \nu \quad (10.6.41)$$

and one has the damped vibration

$$\begin{aligned}
x &= x_o \left(c_1 e^{i\omega_1 t} + c_2 e^{i\omega_2 t} \right) \\
&= x_o e^{-(E/2\eta)t} \left(c_1 e^{ivt} + c_2 e^{-ivt} \right) \\
&= x_o e^{-(E/2\eta)t} \left(A \cos(vt) + B \sin(vt) \right)
\end{aligned} \tag{10.6.42}$$

If, on the other hand, the mass is large or the spring compliant, one gets a pure imaginary root, $\omega = i(E/2\eta) \pm iv$, so that $i\omega$ is real (and less than zero) and one has the aperiodic damping

$$x = x_o \left(c_1 e^{(E/2\eta+iv)t} + c_2 e^{(E/2\eta-iv)t} \right) \tag{10.6.43}$$

10.6.6 Problems

1. Use the differential form of the constitutive equation for a linearly viscoelastic material to derive the *complex compliance*, the *complex modulus*, and the *loss tangent* for a Kelvin material. (put the first two in the form $\alpha + i\beta$). Use your expression for the complex compliance to derive the strain response to a stress $\sigma_o \cos(\omega t)$, in terms of $\sigma_o, \omega, t, E, \eta$, in the form

$$\varepsilon(t) = \sigma_o \left(A \cos \omega t + B \sin \omega t \right)$$

What happens at very low frequencies?

10.7 Temperature-dependent Viscoelastic Materials

Many materials, for example polymeric materials, have a response which is strongly temperature-dependent. Temperature effects can be incorporated into the theory discussed thus far in a simple way by allowing for the coefficients of the differential constitutive equations to be functions of temperature. Thus, Eqn. 10.3.19 can be expressed more generally as

$$p_0(\theta)\sigma + p_1(\theta)\dot{\sigma} + p_2(\theta)\ddot{\sigma} + \dots = q_0(\theta)\varepsilon + q_1(\theta)\dot{\varepsilon} + q_2(\theta)\ddot{\varepsilon} + \dots \quad (10.7.1)$$

where θ denotes temperature. Equivalently, one can allow for the creep and relaxation functions to be functions of temperature in the hereditary integral formulation. Thus Eqns. 10.4.20-21 read

$$\begin{aligned} \varepsilon(t, \theta) &= \sigma(0)J(t, \theta) + \int_0^t J(t - \tau, \theta) \frac{d\sigma(\tau)}{d\tau} d\tau \\ \sigma(t, \theta) &= \varepsilon(0)E(t, \theta) + \int_0^t E(t - \tau, \theta) \frac{d\varepsilon(\tau)}{d\tau} d\tau \end{aligned} \quad (10.7.2)$$

10.7.1 Example: The Maxwell Model

Consider a Maxwell material whose dash-pot viscosity η is a function of temperature θ . The differential constitutive equation is then

$$\sigma + \frac{\eta(\theta)}{\bar{E}} \frac{d\sigma}{dt} = \eta(\theta) \frac{d\varepsilon}{dt} \quad (10.7.3)$$

where \bar{E} is the temperature-independent spring stiffness. This equation is a function of both temperature and time. With temperature a function of time, $\theta = \theta(t)$, it is a linear differential equation with non-constant coefficients. For constant temperature, it has constant coefficients.

Consider first the case of constant temperature. The relaxation modulus and creep compliance functions can be evaluated by applying unit strain and unit stress. From the previous work, one has

$$\begin{aligned} E(t, \theta) &= \bar{E} e^{-t/t_R(\theta)}, \quad t_R(\theta) = \frac{\eta(\theta)}{\bar{E}} \\ J(t, \theta) &= \frac{1}{\bar{E}} + \frac{t}{\eta(\theta)} \end{aligned} \quad (10.7.4)$$

Thus any given material has temperature-dependent relaxation and creep functions.

Consider now the change of variable

$$\xi = A \frac{t}{\eta(\theta)} \quad (10.7.5)$$

where A is any constant (which can be chosen arbitrarily for convenience – see later). This transforms Eqn. 10.7.3 into

$$\sigma(\xi) + \frac{A}{E} \frac{d\sigma}{d\xi} = A \frac{d\varepsilon}{d\xi} \quad (10.7.6)$$

This is now an equation with dependence on only one variable, ξ . From this equation, one obtains relaxation and creep functions

$$\begin{aligned} E(\xi) &= \bar{E} e^{-\xi/t_R}, \quad t_R = \frac{A}{E} \\ J(\xi) &= \frac{1}{E} + \frac{\xi}{A} \end{aligned} \quad (10.7.7)$$

These equations generate **master curves** from which the different temperature-dependent curves 10.7.4 can be obtained.

Example Data

For example, consider a viscosity which varies linearly over the range $-100^\circ\text{C} < \theta < 100^\circ\text{C}$ according to the relation

$$\eta(\theta) = \eta_0 \left[1 - A_\eta \left(\frac{\theta}{\theta_0} - 1 \right) \right] \quad (10.7.8)$$

where η_0 is a constant viscosity, $A_\eta = 0.2$ and $\theta_0 = 20^\circ\text{C}$ (a reference temperature at which $\eta(\theta) = \eta_0$). This function is plotted in Fig. 10.7.1 below.

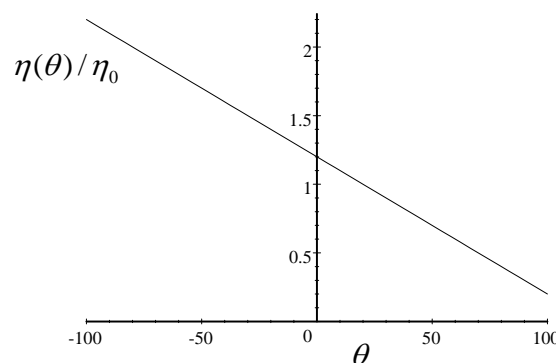

Figure 10.7.1: linear dependence of viscosity on temperature

Also, let $\eta_0 / \bar{E} = m$. The resulting relaxation and creep functions of Eqn. 10.7.4 are plotted in Fig. 10.7.2 below (for $m = 5$).

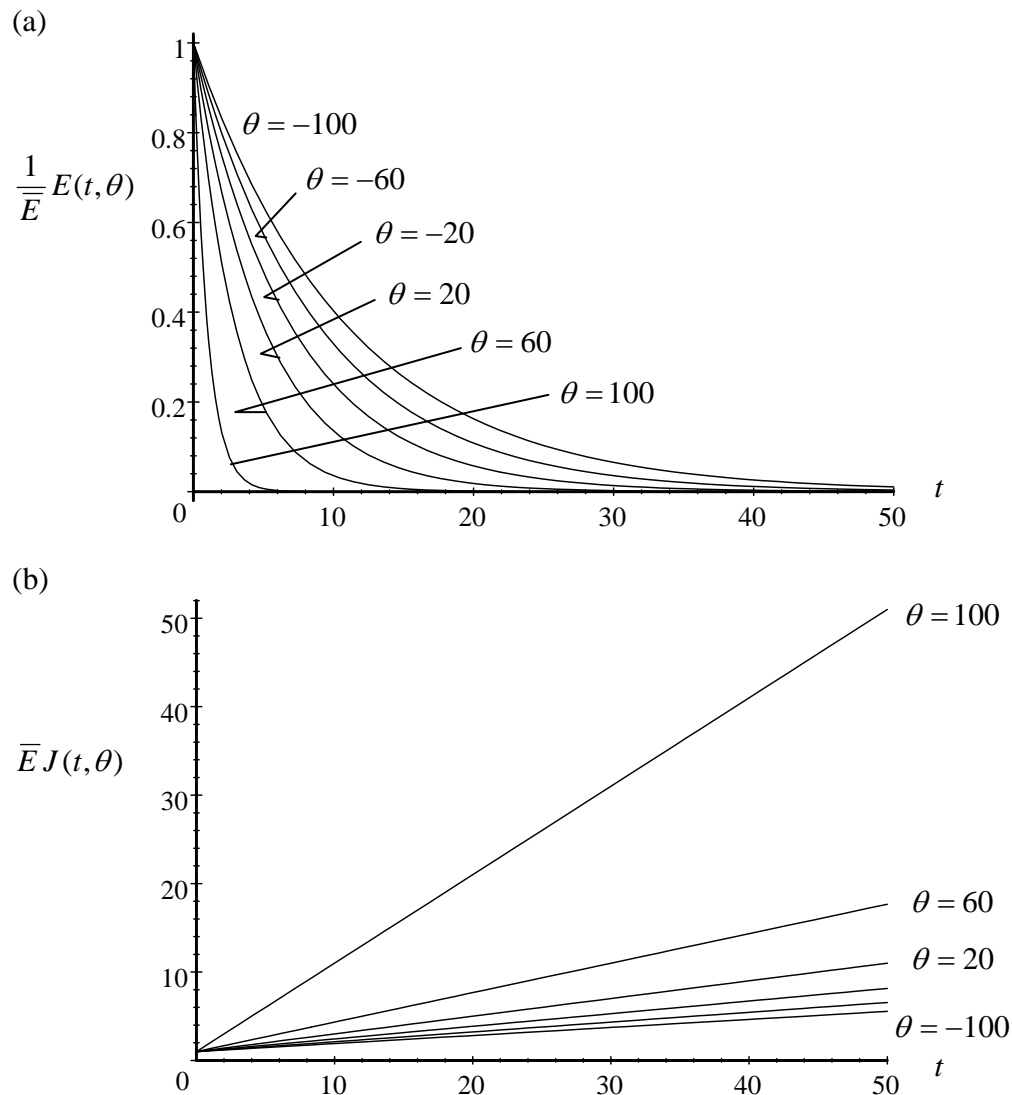

Figure 10.7.2: temperature-dependent functions; (a) relaxation modulus, (b) creep compliance

Note the following, referring to Fig. 10.7.2:

- (i) for temperatures greater than the reference temperature $\theta = \theta_0 = 20^\circ$ (see Eqn. 10.7.8), the viscosity is $\eta(\theta) < \eta_0$. This implies that, for $\theta > \theta_0$, the relaxation times are shorter than for $\theta = \theta_0$ (see Eqn. 10.7.4a), Fig. 10.7.2a, and the slope of the creep curves is greater than for $\theta = \theta_0$ (see Eqn. 10.7.4b), Fig. 10.7.2b.
- (ii) for temperatures smaller than the reference temperature, $\eta(\theta) > \eta_0$. Thus, for $\theta < \theta_0$, the relaxation times are longer than for $\theta = \theta_0$ and the slope of the creep curves is smaller than for $\theta = \theta_0$.

Now choose the constant A in Eqn. 10.7.5 to be equal to η_0 . This ensures that $\xi = t$ at the reference temperature θ_0 (see 10.7.8). In other words, the master curves of Eqn. 10.7.7 and the functions 10.7.4 corresponding to θ_0 coincide (with the t axis and ξ axis coincident).

The master relaxation and creep curves of Eqn. 10.7.7 are now $E(\xi)/\bar{E} = e^{-\xi/m}$ and $\bar{E}J(\xi) = 1 + \xi/m$. These are plotted in Fig. 10.7.3 below (for $m = 5$).

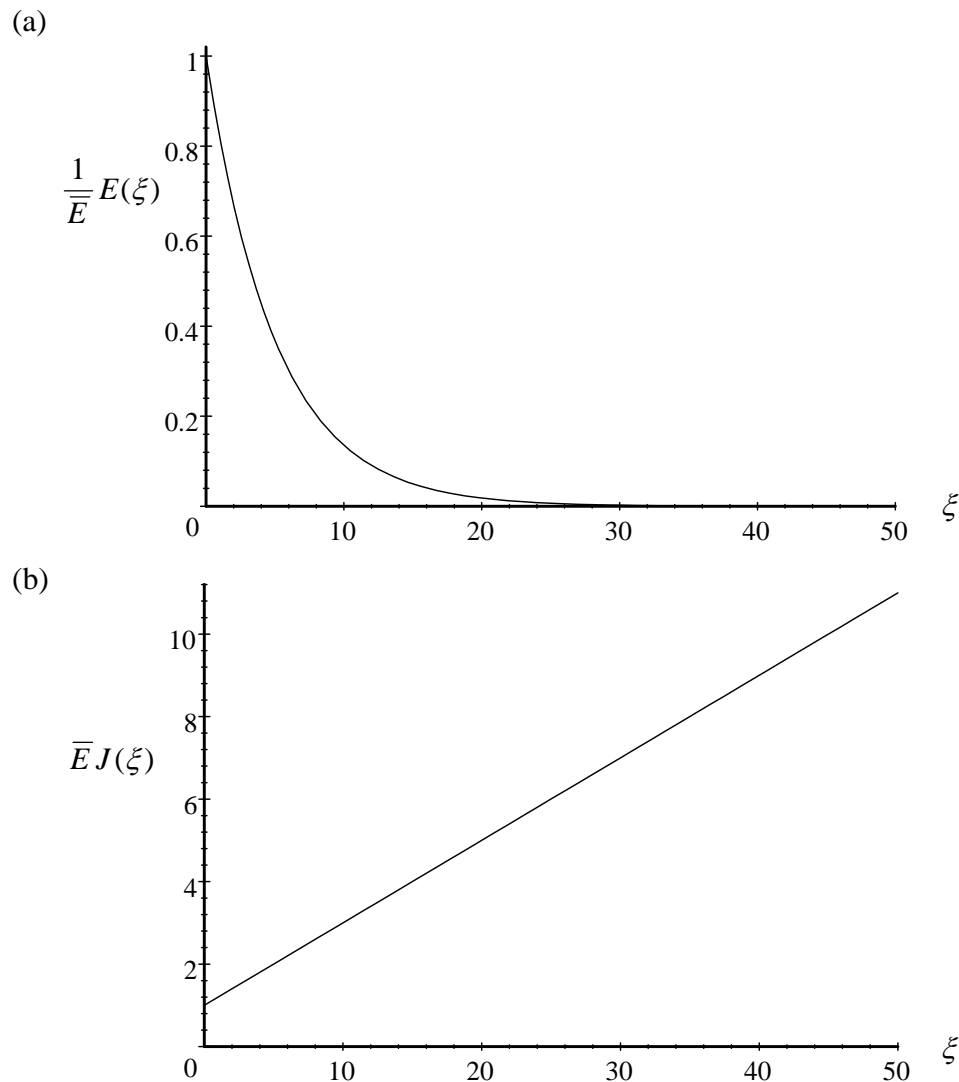

Figure 10.7.3: master curves; (a) relaxation modulus, (b) creep compliance

All the curves of Fig. 10.7.2 collapse onto the master curve of Fig. 10.7.3 as follows:

- (i) the curves corresponding to the reference temperature, $\theta = \theta_0 = 20^\circ$, in Figs. 10.7.2 lie on the master curves (with the t axis and ξ axis coincident)
- (ii) for a curve with $\theta > \theta_0$, if the time axis of Fig. 10.7.2a,b is “stretched” (according to 10.7.5), the curve will come to lie along the $\theta = \theta_0$ curve (and hence on the master

curve); for a curve with $\theta < \theta_0$, if the time axis of Fig. 10.7.2a is “shrunk” (according to 10.7.5), the curve will come to lie along the $\theta = \theta_0$ curve (and hence on the master curve)

10.7.2 Thermorheologically Simple Materials

The fact that the relaxation and creep curves of Fig. 10.7.2 collapsed onto the master curves of Fig. 10.7.3 relied on the change of variable, Eqn. 10.7.5, reducing the time and temperature dependent constitutive relation 10.7.3 to an equation in one variable, ξ , only, Eqn. 10.7.6. This in turn depended critically on the form of the differential equation 10.7.3. For example, if the spring stiffness \bar{E} in the Maxwell model is temperature-dependent, the collapsing of curves is not possible.

Temperature-dependent viscoelastic materials for which this collapsing of curves is possible are called **thermorheologically simple** materials. In this context, the parameter ξ is called the **reduced time**. More generally, the transformation 10.7.5 is expressed in the form

$$\xi = \frac{t}{a_\theta(\theta)} \quad (10.7.9)$$

and the function $a_\theta(\theta)$ is called the **shift factor** function. The shift factor is chosen so that the relaxation and creep curves corresponding to the chosen reference temperature θ_0 coincide (as in the Maxwell model example above), i.e. so that $a_\theta(\theta_0) = 1$.

The relaxation and creep functions now transform as

$$E(t, \theta) \rightarrow E(\xi, \theta_0), \quad J(t, \theta) \rightarrow J(\xi, \theta_0) \quad (10.7.10)$$

For temperatures below the reference temperature, $\theta < \theta_0$, $a_\theta(\theta_0)$ will be greater than 1, and the corresponding relaxation/creep curves collapse onto the master curve by “shrinking” the time axis t , which looks like a “shifting” of the curve “to the left” onto the $\theta = \theta_0$ curve. On the other hand, for $\theta > \theta_0$, $a_\theta(\theta_0) < 1$, and the corresponding curves collapse by a “stretching” of the time axis, which looks like a “shifting” of the curves “to the right” onto the master curve. This is summarised in Fig. 10.7.4 below.

The result of this is that materials at high temperatures and high strain rates behave similarly to materials at low temperatures and low strain rates.

The method discussed can also be used when the temperature is time-dependent, for then the transformation can be expressed as

$$\xi(t) = \int_0^t \frac{d\tau}{a_\theta(\theta(\tau))} \quad (10.7.11)$$

so that

$$\frac{d\xi}{dt} = \frac{1}{a_\theta(\theta(t))} \quad (10.7.12)$$

leading to the same reduced differential equation.

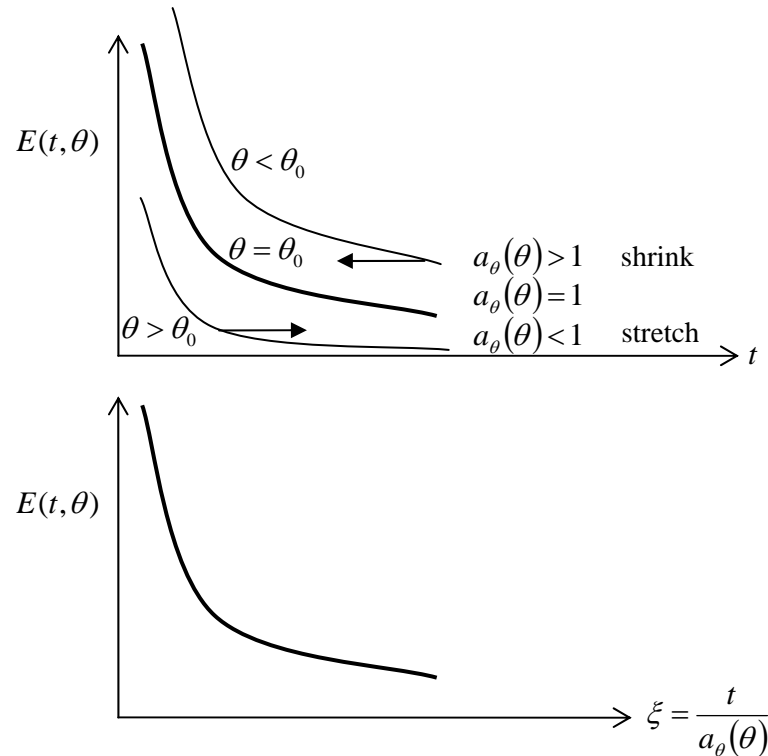

Figure 10.7.4: Relaxation modulus, as a function of (a) time, (b) reduced time

The above discussion has related to the differential constitutive equation 10.7.1. The analysis can also be expressed in terms of hereditary integrals of the form 10.7.2. For example, the equivalent hereditary integral in terms of reduced time, corresponding to the reduced differential equation (see Eqn. 10.7.6 for the Maxwell model equation) is

$$\sigma(\xi) = \int_{-\infty}^{\xi} E(\xi - \tau) \frac{d\varepsilon(\tau)}{d\tau} d\tau \quad (10.7.13)$$

where $E(\xi)$ is as before (see Eqn. 10.7.7 for the Maxwell model expression).