

## 3.5 Plane Stress

This section is concerned with a special two-dimensional state of stress called **plane stress**. It is important for two reasons: (1) it arises in real components (particularly in thin components loaded in certain ways), and (2) it is a two dimensional state of stress, and thus serves as an excellent introduction to more complicated three dimensional stress states.

### 3.5.1 Plane Stress

The state of plane stress is defined as follows:

**Plane Stress:**

If the stress state at a material particle is such that the only non-zero stress components act in one plane only, the particle is said to be in plane stress.

The axes are usually chosen such that the  $x - y$  plane is the plane in which the stresses act, Fig. 3.5.1.

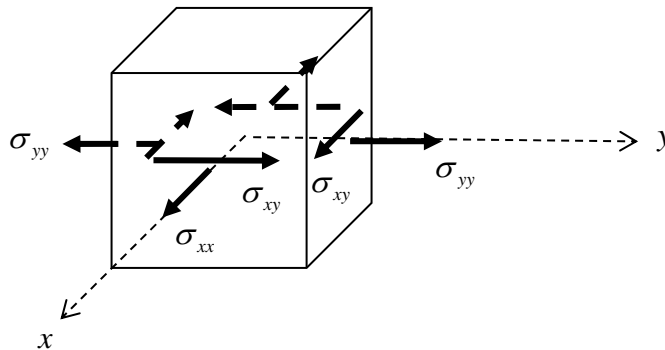

**Figure 3.5.1: non-zero stress components acting in the  $x - y$  plane**

The stress can be expressed in the matrix form 3.4.1.

#### Example

The thick block of uniform material shown in Fig. 3.5.2, loaded by a constant stress  $\sigma_o$  in the  $x$  direction, will have  $\sigma_{xx} = \sigma_o$  and all other components zero everywhere. It is therefore in a state of plane stress.

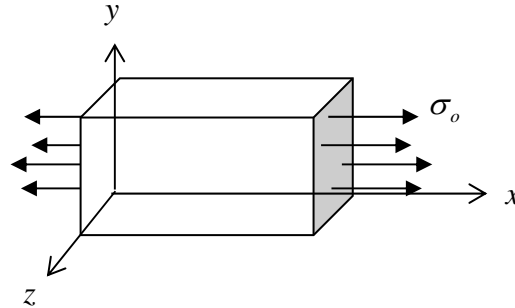

Figure 3.5.2: a thick block of material in plane stress

### 3.5.2 Analysis of Plane Stress

Next are discussed the **stress invariants**, **principal stresses** and **maximum shear stresses** for the two-dimensional plane state of stress, and tools for evaluating them. These quantities are useful because they tell us the complete state of stress at a point in simple terms. Further, these quantities are directly related to the strength and response of materials. For example, the way in which a material plastically (permanently) deforms is often related to the maximum shear stress, the directions in which flaws/cracks grow in materials are often related to the principal stresses, and the energy stored in materials is often a function of the stress invariants.

#### Stress Invariants

A stress invariant is some function of the stress components which is independent of the coordinate system being used; in other words, they have the same value no matter where the  $x - y$  axes are drawn through a point. In a two dimensional space there are two stress invariants, labelled  $I_1$  and  $I_2$ . These are

$$\begin{array}{l} I_1 = \sigma_{xx} + \sigma_{yy} \\ I_2 = \sigma_{xx}\sigma_{yy} - \sigma_{xy}^2 \end{array} \quad \text{Stress Invariants} \quad (3.5.1)$$

These quantities can be proved to be invariant directly from the stress transformation equations, Eqns. 3.4.9 {▲ Problem 1}. Physically, invariance of  $I_1$  and  $I_2$  means that they are the same for any chosen perpendicular planes through a material particle.

Combinations of the stress invariants are also invariant, for example the important quantity

$$\frac{1}{2}I_1 \pm \sqrt{\frac{1}{4}I_1^2 - I_2} = \frac{\sigma_{xx} + \sigma_{yy}}{2} \pm \sqrt{\frac{1}{4}(\sigma_{xx} - \sigma_{yy})^2 + \sigma_{xy}^2} \quad (3.5.2)$$

## Principal Stresses

Consider a material particle for which the stress, with respect to some  $x - y$  coordinate system, is

$$\begin{bmatrix} \sigma_{xx} & \sigma_{xy} \\ \sigma_{yx} & \sigma_{yy} \end{bmatrix} = \begin{bmatrix} 2 & -1 \\ -1 & 1 \end{bmatrix} \quad (3.5.3)$$

The stress acting on different planes through the point can be evaluated using the Stress Transformation Equations, Eqns. 3.4.9, and the results are plotted in Fig. 3.5.3. The original planes are re-visited after rotating  $180^\circ$ .

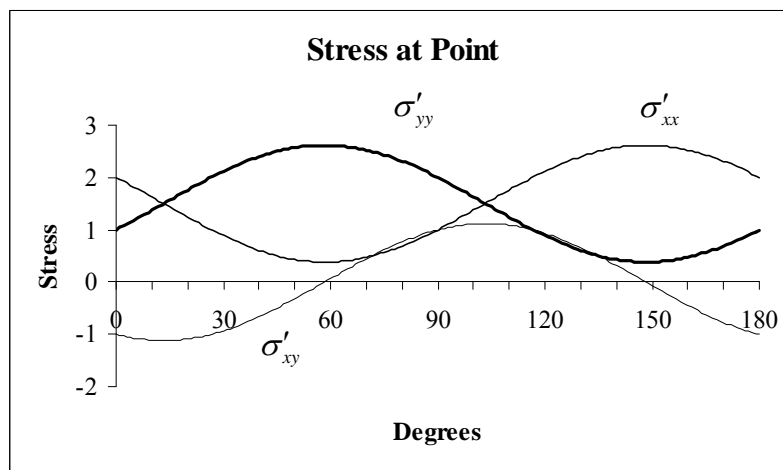

**Figure 3.5.3: stresses on different planes through a point**

It can be seen that there are two perpendicular planes for which the shear stress is zero, for  $\theta \approx 58^\circ$  and  $\theta \approx (58 + 90)^\circ$ . In fact it can be proved that for every point in a material there are two (and only two) perpendicular planes on which the shear stress is zero (see below). These planes are called the **principal planes**. It will also be noted from the figure that the normal stresses acting on the planes of zero shear stress are either a maximum or minimum. Again, this can be proved (see below). These normal stresses are called principal stresses. The principal stresses are labelled  $\sigma_1$  and  $\sigma_2$ , Fig. 3.5.4.

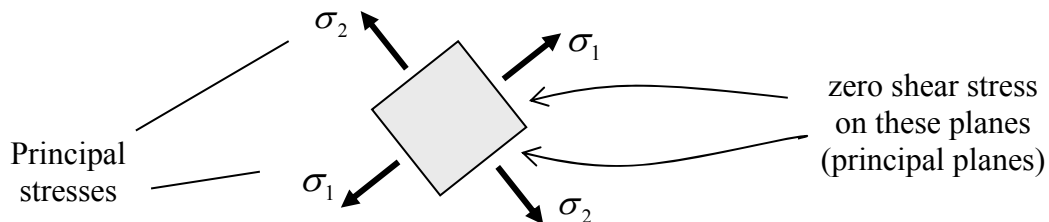

**Figure 3.5.4: principal stresses**

The principal stresses can be obtained by setting  $\sigma'_{xy} = 0$  in the Stress Transformation Equations, Eqns. 3.4.9, which leads to the value of  $\theta$  for which the planes have zero shear stress:

$$\boxed{\tan 2\theta = \frac{2\sigma_{xy}}{\sigma_{xx} - \sigma_{yy}}} \quad \text{Location of Principal Planes} \quad (3.5.4)$$

For the example stress state, Eqn. 3.5.3, this leads to

$$\theta = \frac{1}{2} \arctan(-2)$$

and so the perpendicular planes are at  $\theta = -31.72^\circ$  ( $148.28^\circ$ ) and  $\theta = 58.3^\circ$ .

Explicit expressions for the principal stresses can be obtained by substituting the value of  $\theta$  from Eqn. 3.5.4 into the Stress Transformation Equations, leading to (see the Appendix to this section, §3.5.7)

$$\boxed{\begin{aligned} \sigma_1 &= \frac{1}{2}(\sigma_{xx} + \sigma_{yy}) + \sqrt{\frac{1}{4}(\sigma_{xx} - \sigma_{yy})^2 + \sigma_{xy}^2} \\ \sigma_2 &= \frac{1}{2}(\sigma_{xx} + \sigma_{yy}) - \sqrt{\frac{1}{4}(\sigma_{xx} - \sigma_{yy})^2 + \sigma_{xy}^2} \end{aligned}} \quad \text{Principal Stresses} \quad (3.5.5)$$

For the example stress state Eqn.3.5.3, one has

$$\sigma_1 = \frac{3 + \sqrt{5}}{2} \approx 2.62, \quad \sigma_2 = \frac{3 - \sqrt{5}}{2} \approx 0.38$$

Note here that one uses the symbol  $\sigma_1$  to represent the maximum principal stress and  $\sigma_2$  to represent the minimum principal stress. By maximum, it is meant the algebraically largest stress so that, for example,  $+1 > -3$ .

From Eqns. 3.5.2, 3.5.5, the principal stresses are invariant; they are intrinsic features of the stress state at a point and do not depend on the coordinate system used to describe the stress state.

The question now arises: why are the principal stresses so important? One part of the answer is that the maximum principal stress is the largest normal stress acting on any plane through a material particle. This can be proved by differentiating the stress transformation formulae with respect to  $\theta$ ,

$$\begin{aligned}
 \frac{d\sigma'_{xx}}{d\theta} &= -\sin 2\theta(\sigma_{xx} - \sigma_{yy}) + 2\cos 2\theta\sigma_{xy} \\
 \frac{d\sigma'_{yy}}{d\theta} &= +\sin 2\theta(\sigma_{xx} - \sigma_{yy}) - 2\cos 2\theta\sigma_{xy} \\
 \frac{d\sigma'_{xy}}{d\theta} &= -\cos 2\theta(\sigma_{xx} - \sigma_{yy}) - 2\sin 2\theta\sigma_{xy}
 \end{aligned}
 \tag{3.5.6}$$

The maximum/minimum values can now be obtained by setting these expressions to zero. One finds that the normal stresses are a maximum/minimum at the very value of  $\theta$  in Eqn. 3.5.4 – the value of  $\theta$  for which the shear stresses are zero – the principal planes.

Very often the only thing one knows about the stress state at a point are the principal stresses. In that case one can derive a very useful formula as follows: align the coordinate axes in the principal directions, so

$$\sigma_{xx} = \sigma_1, \quad \sigma_{yy} = \sigma_2, \quad \sigma_{xy} = 0 \tag{3.5.7}$$

Using the transformation formulae with the relations  $\sin^2 \theta = \frac{1}{2}(1 - \cos 2\theta)$  and  $\cos^2 \theta = \frac{1}{2}(1 + \cos 2\theta)$  then leads to

$$\begin{aligned}
 \sigma'_{xx} &= \frac{1}{2}(\sigma_1 + \sigma_2) + \frac{1}{2}(\sigma_1 - \sigma_2)\cos 2\theta \\
 \sigma'_{yy} &= \frac{1}{2}(\sigma_1 + \sigma_2) - \frac{1}{2}(\sigma_1 - \sigma_2)\cos 2\theta \\
 \sigma'_{xy} &= -\frac{1}{2}(\sigma_1 - \sigma_2)\sin 2\theta
 \end{aligned}
 \tag{3.5.8}$$

Here,  $\theta$  is measured *from* the principal directions, as illustrated in Fig. 3.5.5.

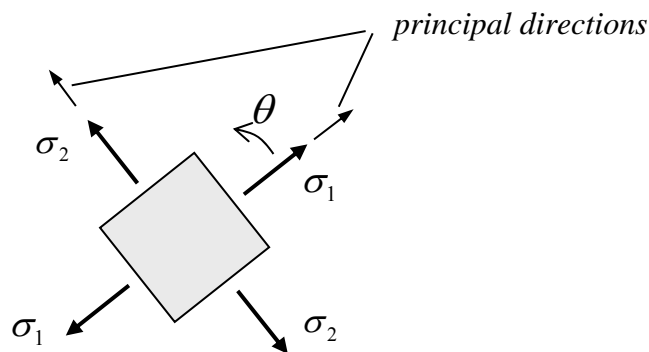

**Figure 3.5.5: principal stresses and principal directions**

### The Third Principal Stress

Although plane stress is essentially a two-dimensional stress-state, it is important to keep in mind that any real particle is three-dimensional. The stresses acting *on* the  $x - y$  plane are the normal stress  $\sigma_{zz}$  and the shear stresses  $\sigma_{zx}$  and  $\sigma_{zy}$ , Fig. 3.5.6. These are all zero (in plane stress). It was discussed above how the principal stresses occur on planes of zero shear stress. Thus the  $\sigma_{zz}$  stress is also a principal stress. Technically speaking, there are always three principal stresses in three dimensions, and (at least) one of these will be zero in plane stress. This fact will be used below in the context of maximum shear stress.

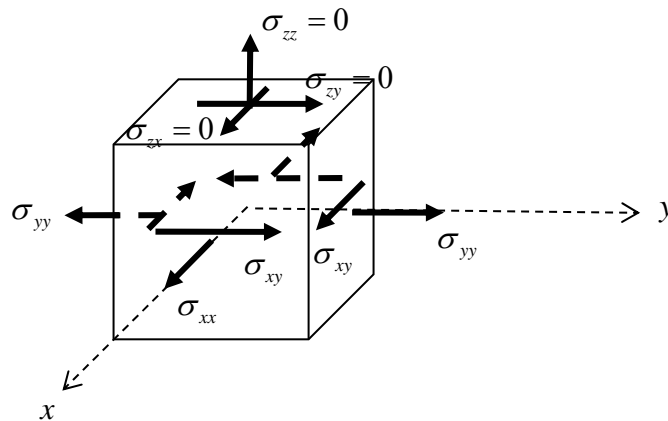

**Figure 3.5.6: stresses acting on the  $x - y$  plane**

### Maximum Shear Stress

Eqns. 3.5.8 can be used to derive an expression for the maximum shear stress. Differentiating the expression for shear stress with respect to  $\theta$ , setting to zero and solving, shows that the maximum/minimum occurs at  $\theta = \pm 45^\circ$ , in which case

$$\sigma_{xy}|_{\theta=+45} = -\frac{1}{2}(\sigma_1 - \sigma_2), \quad \sigma_{xy}|_{\theta=-45} = +\frac{1}{2}(\sigma_1 - \sigma_2)$$

or

$$\boxed{\max(\sigma_{xy}) = \frac{1}{2}|\sigma_1 - \sigma_2|} \quad \text{Maximum Shear Stress} \quad (3.5.9)$$

Thus the shear stress reaches a maximum on planes which are oriented at  $\pm 45^\circ$  to the principal planes, and the value of the shear stress acting on these planes is as given above. Note that the formula Eqn. 3.5.9 does not let one know in which *direction* the shear stresses are acting but this is not usually an important issue. Many materials respond in certain ways when the maximum shear stress reaches a critical value, and the actual direction of shear

stress is unimportant. The direction of the maximum principal stress is, on the other hand, important – a material will in general respond differently according to whether the normal stress is compressive or tensile.

The normal stress acting on the planes of maximum shear stress can be obtained by substituting  $\theta = \pm 45^\circ$  back into the formulae for normal stress in Eqn. 3.5.8, and one sees that

$$\sigma'_{xx} = \sigma'_{yy} = (\sigma_1 + \sigma_2)/2 \quad (3.5.10)$$

The results of this section are summarised in Fig. 3.5.7.

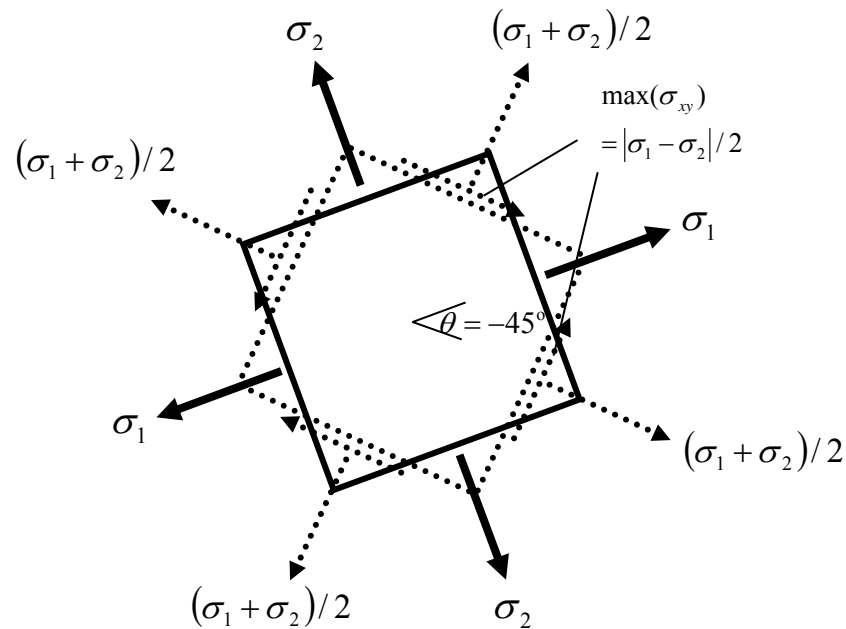
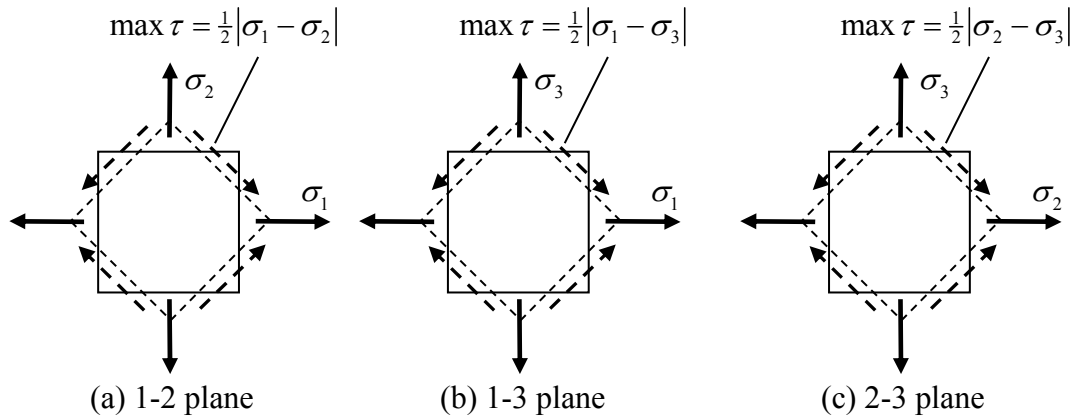

**Figure 3.5.7: principal stresses and maximum shear stresses acting in the  $x - y$  plane**

The maximum shear stress in the  $x - y$  plane was calculated above, Eqn. 3.5.9. This is not necessarily the maximum shear stress acting at the material particle. In general, it can be shown that the maximum shear stress is the maximum of the following three terms (see Part III, §3.4.3):

$$\frac{1}{2}|\sigma_1 - \sigma_2|, \quad \frac{1}{2}|\sigma_1 - \sigma_3|, \quad \frac{1}{2}|\sigma_2 - \sigma_3|$$

The first term is the maximum shear stress in the 1–2 plane, i.e. the plane containing the  $\sigma_1$  and  $\sigma_2$  stresses (and given by Eqn. 3.5.9). The second term is the maximum shear stress in the 1–3 plane and the third term is the maximum shear stress in the 2–3 plane. These are sketched in Fig. 3.5.8 below.



**Figure 3.5.8: principal stresses and maximum shear stresses**

In the case of plane stress,  $\sigma_3 = \sigma_{zz} = 0$ , and the maximum shear stress will be (see the Appendix to this section, §3.5.7)

$$\max \left\{ \frac{1}{2} |\sigma_1 - \sigma_2|, \frac{1}{2} |\sigma_1|, \frac{1}{2} |\sigma_2| \right\} \quad (3.5.11)$$

### 3.5.3 Stress Boundary Conditions

When solving problems, information is usually available on what is happening at the boundaries of materials. This information is called the **boundary conditions**. Information is usually not available on what is happening in the interior of the material – information there is obtained by solving the equations of mechanics.

A number of different conditions can be known at a boundary, for example it might be known that a certain part of the boundary is fixed so that the displacements there are zero. This is known as a **displacement boundary condition**. On the other hand the stresses over a certain part of the material boundary might be known. These are known as **stress boundary conditions** – this case will be examined here.

#### General Stress Boundary Conditions

It has been seen already that, when one material contacts a second material, a force, or distribution of stress arises. This force  $F$  will have arbitrary direction, Fig. 3.5.9a, and can be decomposed into the sum of a normal stress distribution  $\sigma_N$  and a shear distribution  $\sigma_S$ , Fig. 3.5.9b. One can introduce a coordinate system to describe the applied stresses, for example the  $x - y$  axes shown in Fig. 3.5.9c (the axes are most conveniently defined to be normal and tangential to the boundary).



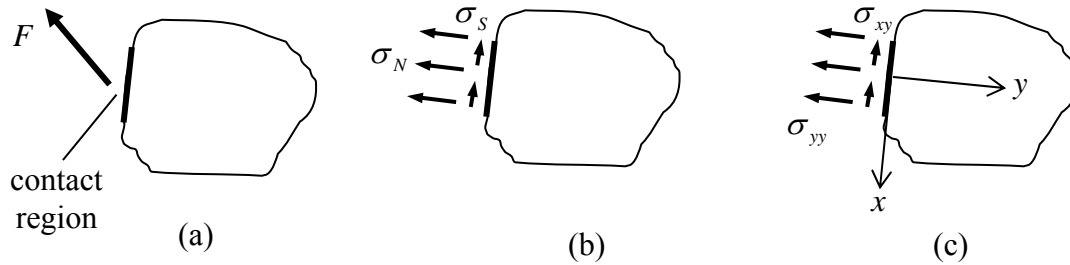

**Figure 3.5.9: Stress boundary conditions; (a) force acting on material due to contact with a second material, (b) the resulting normal and shear stress distributions, (c) applied stresses as stress components in a given coordinate system**

Figure 3.5.10 shows the same component as Fig. 3.5.9. Shown in detail is a small material element at the boundary. From equilibrium of the element, stresses  $\sigma_{xy}$ ,  $\sigma_{yy}$ , equal to the applied stresses, must be acting inside the material, Fig. 3.5.10a. Note that the **tangential stresses**, which are the  $\sigma_{xx}$  stresses in this example, can take on any value and the element will still be in equilibrium with the applied stresses, Fig. 3.5.10b.

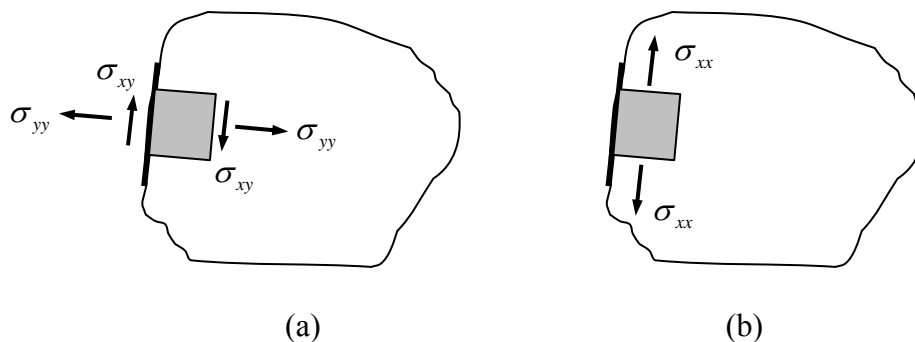

**Figure 3.5.10: Stresses acting on a material element at the boundary, (a) normal and shear stresses, (b) tangential stresses**

Thus, if the applied stresses are *known*, then so also are the normal and shear stresses acting at the boundary of the material.

### Stress Boundary Conditions at a Free Surface

A free surface is a surface that has “nothing” on one side and so there is nothing to provide reaction forces. Thus there must also be no normal or shear stress on the other side (the inside).

This leads to the following, Fig. 3.5.11:

**Stress boundary conditions at a free surface:**  
the normal and shear stress at a free surface are zero

This simple fact is used again and again to solve practical problems.

Again, the stresses acting normal to any other plane at the surface do not have to be zero – they can be balanced as, for example, the tangential stresses  $\sigma_T$  and the stress  $\bar{\sigma}$  in Fig. 3.5.11.

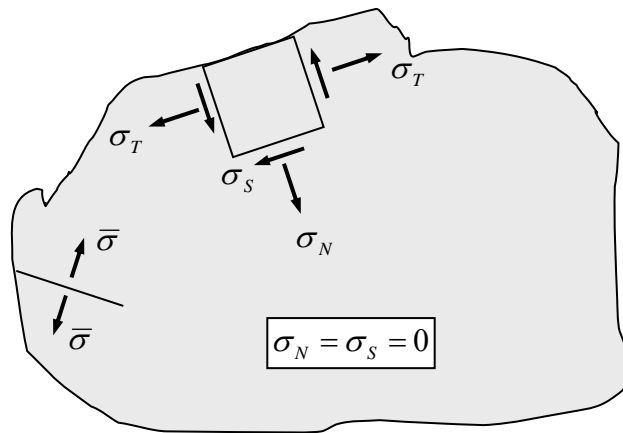

**Figure 3.5.11: A free surface - the normal and shear stresses there are zero**

### Atmospheric Pressure

There *is* something acting on the outside “free” surfaces of materials – the atmospheric pressure. This is a type of stress which is **hydrostatic**, that is, it acts normal at all points, as shown in Fig. 3.5.12. Also, it does not vary much. This pressure is present when one characterises a material, that is, when its material properties are determined from tests and so on, for example, its Young’s Modulus (see Chapter 5). The atmospheric pressure is therefore a datum – stresses are really measured relative to this value, and so the atmospheric pressure is ignored.

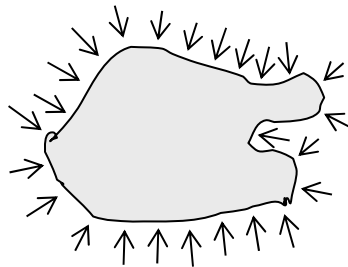

**Figure 3.5.12: a material subjected to atmospheric pressure**

### 3.5.4 Thin Components

Consider a thin component as shown in Fig. 3.5.13. With the coordinate axes aligned as shown, and with the large face free of loading, one has  $\sigma_{zx} = \sigma_{zy} = \sigma_{zz} = 0$ . Strictly speaking, these stresses are zero *only* at the free surfaces of the material, but because it is thin, these stresses should not vary much from zero within. Taking the “ $z$ ” stresses to be identically zero throughout the material, the component is in a state of plane stress<sup>1</sup>. On the other hand, were the sheet not so thin, the stress components that were zero at the free-surfaces might well deviate significantly from zero deep within the material and one could not safely argue that the component was in a state of plane stress.

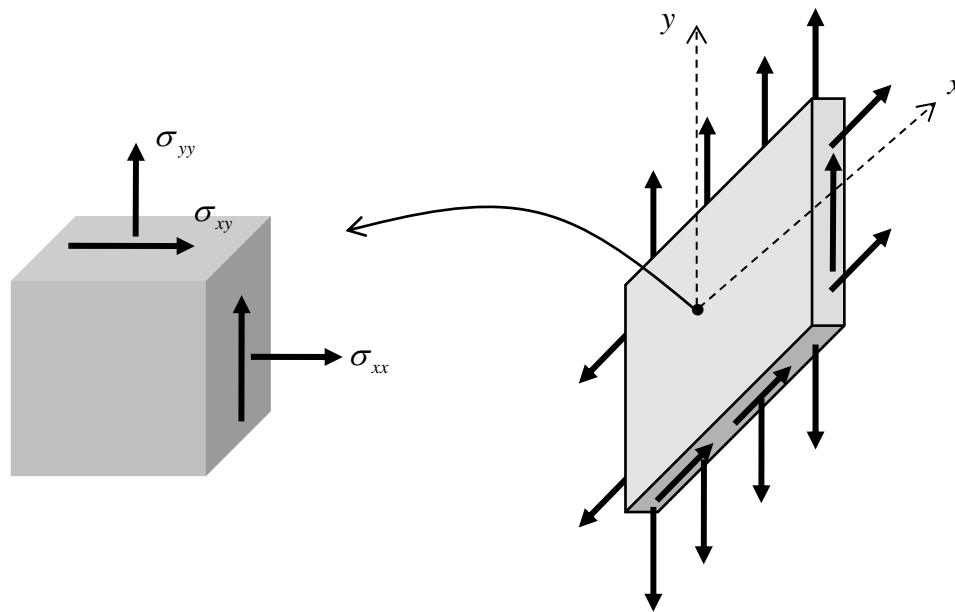

**Figure 3.5.13: a thin material loaded in-plane, leading to a state of plane stress**

When analysing plane stress states, only one cross section of the material need be considered. This is illustrated in Fig. 3.5.14.

<sup>1</sup> it can be shown that, when the applied stresses  $\sigma_{xx}$ ,  $\sigma_{yy}$ ,  $\sigma_{xy}$  vary only *linearly* over the thickness of the component, the stresses  $\sigma_{zz}$ ,  $\sigma_{zx}$ ,  $\sigma_{zy}$  are exactly zero throughout the component, otherwise they are only approximately zero

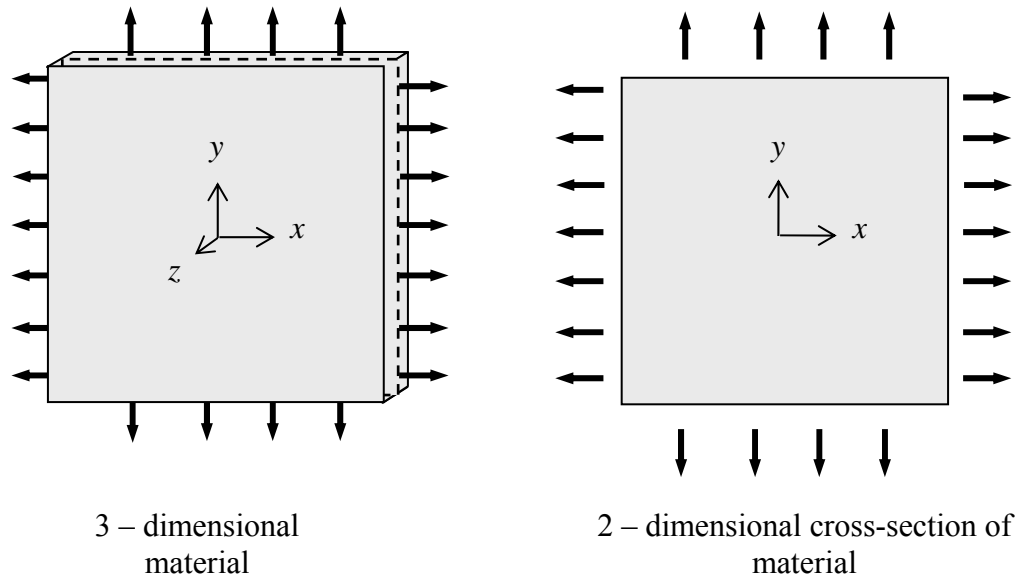

**Figure 3.5.14: one two-dimensional cross-section of material**

Note that, although the stress normal to the plane,  $\sigma_{zz}$ , is zero, the three dimensional sheet of material *is* deforming in this direction – it will obviously be getting thinner under the tensile loading shown in Fig. 3.5.14.

Note that plane stress arises in *all* thin materials (loaded in –plane), no matter what they are made of.

### 3.5.5 Mohr's Circle

Otto Mohr devised a way of describing the state of stress at a point using a single diagram, called the **Mohr's circle**.

To construct the Mohr circle, first introduce the **stress coordinates**  $(\sigma, \tau)$ , Fig. 3.5.15; the abscissae (horizontal) are the normal stresses  $\sigma$  and the ordinates (vertical) are the shear stresses  $\tau$ . On the horizontal axis, locate the principal stresses  $\sigma_1, \sigma_2$ , with  $\sigma_1 > \sigma_2$ . Next, draw a circle, centred at the average principal stress  $(\sigma, \tau) = ((\sigma_1 + \sigma_2)/2, 0)$ , having radius  $(\sigma_1 - \sigma_2)/2$ .

The normal and shear stresses acting on a single plane are represented by a single point on the Mohr circle. The normal and shear stresses acting on two perpendicular planes are represented by two points, one at *each end of a diameter* on the Mohr circle. Two such diameters are shown in the figure. The first is horizontal. Here, the stresses acting on two perpendicular planes are  $(\sigma, \tau) = (\sigma_1, 0)$  and  $(\sigma, \tau) = (\sigma_2, 0)$  and so this diameter represents the principal planes/stresses.

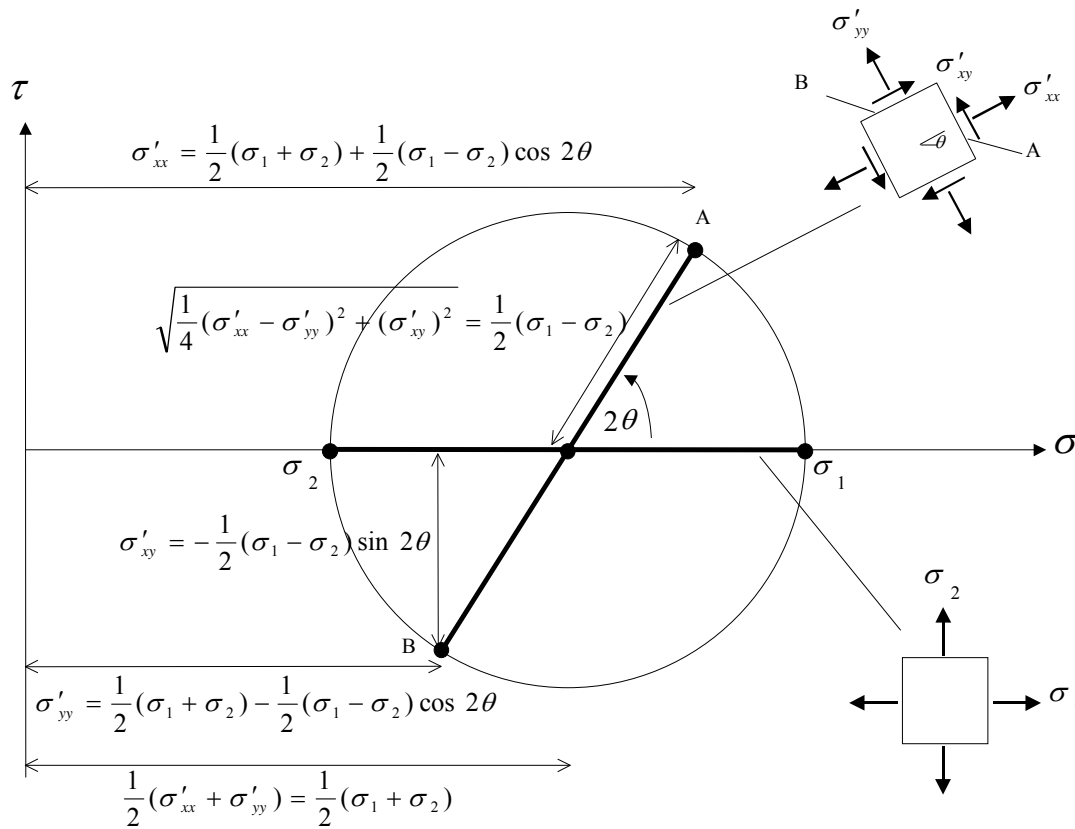

**Figure 3.5.15: Mohr's Circle**

The stresses on planes rotated by an amount  $\theta$  from the principal planes are given by Eqn. 3.5.8. Using elementary trigonometry, these stresses are represented by the points A and B in Fig. 3.5.15. Note that a rotation of  $\theta$  in the physical plane corresponds to a rotation of  $2\theta$  in the Mohr diagram.

Note also that the conventional labeling of shear stress has to be altered when using the Mohr diagram. On the Mohr circle, a shear stress is positive if it yields a clockwise moment about the centre of the element, and is "negative" when it yields a negative moment. For example, at point A the shear stress is "positive" ( $\tau > 0$ ), which means the direction of shear on face A of the element is actually opposite to that shown. This agrees with the formula

$\sigma'_{xy} = -\frac{1}{2}(\sigma_1 - \sigma_2)\sin 2\theta$ , which is less than zero for  $\sigma_1 > \sigma_2$  and  $\theta \leq 90^\circ$ . At point B the shear stress is "negative" ( $\tau < 0$ ), which again agrees with formula.

### 3.5.6 Problems

1. Prove that the function  $\sigma_x + \sigma_y$ , i.e. the sum of the normal stresses acting at a point, is a stress invariant. [Hint: add together the first two of Eqns. 3.4.9.]

2. Consider a material in plane stress conditions. An element at a free surface of this material is shown below left. Taking the coordinate axes to be orthogonal to the surface as shown (so that the tangential stress is  $\sigma_{xx}$ ), one has

$$\begin{bmatrix} \sigma_{xx} & \sigma_{xy} \\ \sigma_{yx} & \sigma_{yy} \end{bmatrix} = \begin{bmatrix} \sigma_{xx} & 0 \\ 0 & 0 \end{bmatrix}$$

- (a) what are the two in-plane principal stresses at the point? Which is the maximum and which is the minimum?  
 (b) examine planes inclined at  $45^\circ$  to the free surface, as shown below right. What are the stresses acting on these planes and what have they got to do with maximum shear stress?

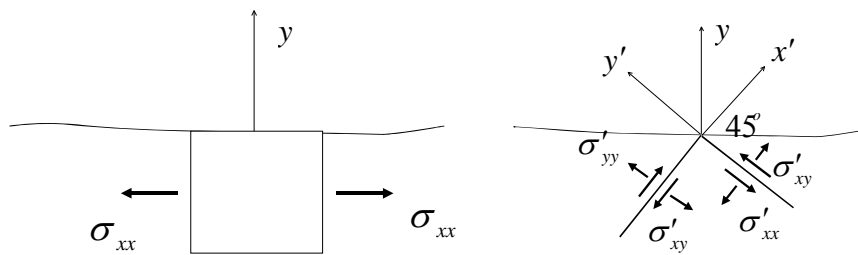

3. The stresses at a point in a state of plane stress are given by

$$\begin{bmatrix} \sigma_{xx} & \sigma_{xy} \\ \sigma_{yx} & \sigma_{yy} \end{bmatrix} = \begin{bmatrix} -1 & 3 \\ 3 & 2 \end{bmatrix}$$

- (a) Draw a little box to represent the point and draw some arrows to indicate the magnitude and direction of the stresses acting at the point.  
 (b) What relationship exists between  $Oxy$  and a second coordinate set  $Ox'y'$ , such that the shear stresses are zero in  $Ox'y'$ ?  
 (c) Find the two in-plane principal stresses.  
 (d) Draw another box whose sides are aligned to the principal directions and draw some arrows to indicate the magnitude and direction of the principal stresses acting at the point.  
 (e) Check that the sum of the normal stresses at the point is an invariant.
4. A material particle is subjected to a state of stress given by

$$[\sigma_{ij}] = \begin{bmatrix} \alpha & \alpha & 0 \\ \alpha & \alpha & 0 \\ 0 & 0 & 0 \end{bmatrix}$$

Find the principal stresses (all three), maximum shear stresses (see Eqn. 3.5.11), and the direction of the planes on which these stresses act.

5. Consider the following state of stress (with respect to an  $x, y, z$  coordinate system):

$$\begin{bmatrix} 0 & \tau & 0 \\ \tau & 0 & 0 \\ 0 & 0 & 0 \end{bmatrix}$$

- (a) Use the stress transformation equations to derive the stresses acting on planes obtained from the original planes by a counterclockwise rotation of  $45^\circ$  about  $z$  axis.  
 (b) What is the maximum normal stress acting at the point?  
 (c) What is the maximum shear stress? On what plane(s) does it act? (See Eqn. 3.5.11.)

6. Consider the two dimensional stress state

$$[\sigma_{ij}] = \begin{bmatrix} \alpha & 0 \\ 0 & \alpha \end{bmatrix}$$

Show that this is an **isotropic state of stress**, that is, the stress components are the same on *all* planes through a material particle.

7. (a) Is a trampoline (the material you jump on) in a state of plane stress? When someone is actually jumping on it?  
 (b) Is a picture hanging on a wall in a state of plane stress?  
 (c) Is a glass window in a state of plane stress? On a very windy day?  
 (d) A piece of rabbit skin is stretched in a testing machine – is it in a state of plane stress?

### 3.5.7 Appendix to §3.5

#### A Note on the Formulae for Principal Stresses

To derive Eqns. 3.5.5, first rewrite the transformation equations in terms of  $2\theta$  using  $\sin^2 \theta = \frac{1}{2}(1 - \cos 2\theta)$  and  $\cos^2 \theta = \frac{1}{2}(1 + \cos 2\theta)$  to get

$$\begin{aligned} \sigma'_{xx} &= \frac{1}{2}(1 + \cos 2\theta)\sigma_{xx} + \frac{1}{2}(1 - \cos 2\theta)\sigma_{yy} + \sin 2\theta\sigma_{xy} \\ \sigma'_{yy} &= \frac{1}{2}(1 - \cos 2\theta)\sigma_{xx} + \frac{1}{2}(1 + \cos 2\theta)\sigma_{yy} - \sin 2\theta\sigma_{xy} \\ \sigma'_{xy} &= \frac{1}{2}\sin 2\theta(\sigma_{yy} - \sigma_{xx}) + \cos 2\theta\sigma_{xy} \end{aligned}$$

Next, from Eqn. 3.5.4,

$$\sin 2\theta = \frac{2\sigma_{xy}}{\sqrt{(\sigma_{xx} - \sigma_{yy})^2 + 4\sigma_{xy}^2}}, \quad \cos 2\theta = \frac{\sigma_{xx} - \sigma_{yy}}{\sqrt{(\sigma_{xx} - \sigma_{yy})^2 + 4\sigma_{xy}^2}}$$

Substituting into the rewritten transformation formulae then leads to

$$\begin{aligned}\sigma'_{xx} &= \frac{1}{2}(\sigma_{xx} + \sigma_{yy}) + \sqrt{\frac{1}{4}(\sigma_{xx} - \sigma_{yy})^2 + \sigma_{xy}^2} \\ \sigma'_{yy} &= \frac{1}{2}(\sigma_{xx} + \sigma_{yy}) - \sqrt{\frac{1}{4}(\sigma_{xx} - \sigma_{yy})^2 + \sigma_{xy}^2} \\ \sigma'_{xy} &= 0\end{aligned}$$

Here  $\sigma'_{xx} > \sigma'_{yy}$  so that the maximum principal stress is  $\sigma_1 = \sigma'_{xx}$  and the minimum principal stress is  $\sigma_2 = \sigma'_{yy}$ . Here it is implicitly assumed that  $\tan 2\theta > 0$ , i.e. that  $0 < 2\theta < 90$  or  $180 < 2\theta < 270$ . On the other hand one could assume that  $\tan 2\theta < 0$ , i.e. that  $90 < 2\theta < 180$  or  $270 < 2\theta < 360$ , in which case one arrives at the formulae

$$\begin{aligned}\sigma'_{xx} &= \frac{1}{2}(\sigma_{xx} + \sigma_{yy}) - \sqrt{\frac{1}{4}(\sigma_{xx} - \sigma_{yy})^2 + \sigma_{xy}^2} \\ \sigma'_{yy} &= \frac{1}{2}(\sigma_{xx} + \sigma_{yy}) + \sqrt{\frac{1}{4}(\sigma_{xx} - \sigma_{yy})^2 + \sigma_{xy}^2}\end{aligned}$$

The results can be summarised as Eqn. 3.5.5,

$$\begin{aligned}\sigma_1 &= \frac{1}{2}(\sigma_{xx} + \sigma_{yy}) + \sqrt{\frac{1}{4}(\sigma_{xx} - \sigma_{yy})^2 + \sigma_{xy}^2} \\ \sigma_2 &= \frac{1}{2}(\sigma_{xx} + \sigma_{yy}) - \sqrt{\frac{1}{4}(\sigma_{xx} - \sigma_{yy})^2 + \sigma_{xy}^2}\end{aligned}$$

These formulae do not tell one on which of the two principal planes the maximum principal stress acts. This might not be an important issue, but if this information is required one needs to go directly to the stress transformation equations. In the example stress state, Eqn. 3.5.3, one has

$$\begin{aligned}\sigma'_{xx} &= \cos^2 \theta(2) + \sin^2 \theta(1) + \sin 2\theta(-1) \\ \sigma'_{yy} &= \sin^2 \theta(2) + \cos^2 \theta(1) - \sin 2\theta(-1)\end{aligned}$$

For  $\theta = -31.72^\circ$  ( $148.28^\circ$ ),  $\sigma'_{xx} = 2.62$  and  $\sigma'_{yy} = 0.38$ . So one has the situation shown below.



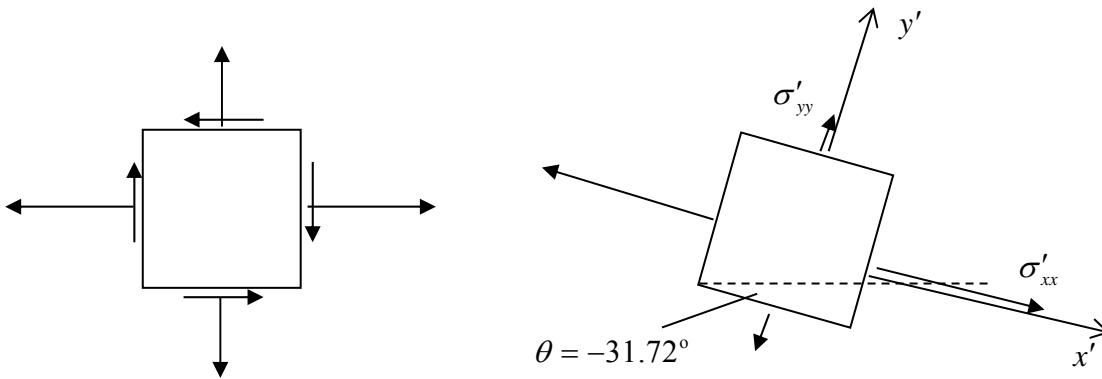

If one takes the other angle,  $\theta = 58.3^\circ$ , one has  $\sigma'_{xx} = 0.38$  and  $\sigma'_{yy} = 2.62$ , and the situation below

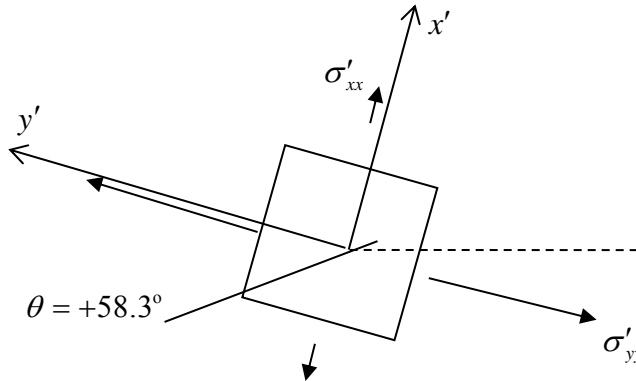

### A Note on the Maximum Shear Stress

Shown below left is a box element with sides perpendicular to the 1,2, z axes, i.e. aligned with the principal directions. The stresses in the new  $x', y'$  axis system shown are given by Eqns. 3.5.8, with  $\theta$  measured from the principal directions:

$$\begin{aligned}\sigma'_{xx} &= \frac{1}{2}(\sigma_1 + \sigma_2) + \frac{1}{2}(\sigma_1 - \sigma_2)\cos 2\theta \\ \sigma'_{yy} &= \frac{1}{2}(\sigma_1 + \sigma_2) - \frac{1}{2}(\sigma_1 - \sigma_2)\cos 2\theta \\ \sigma'_{xy} &= -\frac{1}{2}(\sigma_1 - \sigma_2)\sin 2\theta\end{aligned}$$

Now as well as rotating around in the 1–2 plane through an angle  $\theta$ , rotate also in the  $x', z$  plane through an angle  $\gamma$  (see below right). This rotation leads to the new stresses

$$\begin{aligned}\hat{\sigma}_{xx} &= \cos^2 \gamma \sigma'_{xx} + \sin^2 \gamma \sigma_{zz} + \sin 2\gamma \sigma_{x'z} \\ \hat{\sigma}_{zz} &= \sin^2 \gamma \sigma'_{xx} + \cos^2 \gamma \sigma_{zz} - \sin 2\gamma \sigma_{x'z} \\ \hat{\sigma}_{xz} &= \sin \gamma \cos \gamma (\sigma_{zz} - \sigma'_{xx}) + \cos 2\gamma \sigma_{x'z}\end{aligned}$$

In plane stress,  $\sigma_{zz} = \sigma_{x'z} = 0$ , so one has the stresses

$$\hat{\sigma}_{xx} = \cos^2 \gamma \sigma'_{xx}, \quad \hat{\sigma}_{yy} = \sin^2 \gamma \sigma'_{xx}, \quad \hat{\sigma}_{xy} = -\frac{1}{2} \sin 2\gamma \sigma'_{xx}$$

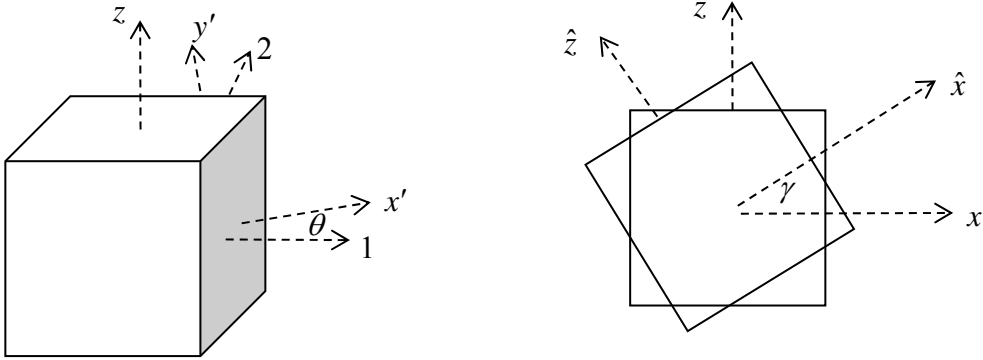

The shear stress can be written out in full:

$$\hat{\sigma}_{xy}(\gamma, \theta) = -\frac{1}{2} \sin 2\gamma \left[ \frac{1}{2}(\sigma_1 + \sigma_2) + \frac{1}{2}(\sigma_1 - \sigma_2) \cos 2\theta \right].$$

This is a function of two variables; its minimum value can be found by setting the partial derivatives with respect to these variables to zero. Differentiating,

$$\begin{aligned}\partial \hat{\sigma}_{xy} / \partial \gamma &= -\cos 2\gamma \left[ \frac{1}{2}(\sigma_1 + \sigma_2) + \frac{1}{2}(\sigma_1 - \sigma_2) \cos 2\theta \right] \\ \partial \hat{\sigma}_{xy} / \partial \theta &= -\frac{1}{2} \sin 2\gamma [-(\sigma_1 - \sigma_2) \sin 2\theta]\end{aligned}$$

Setting to zero gives the solutions  $\sin 2\theta = 0$ ,  $\cos 2\gamma = 0$ , i.e.  $\theta = 0$ ,  $\gamma = 45^\circ$ . Thus the maximum shear stress occurs at  $45^\circ$  to the 1-2 plane, and in the 1-z, i.e. 1-3 plane (as in Fig. 3.5.8b). The value of the maximum shear stress here is then  $|\hat{\sigma}_{xy}| = \left| \frac{1}{2} \sigma_1 \right|$ , which is the expression in Eqn. 3.5.11.