

# 4 2D Elastostatic Problems in Polar Coordinates

Many problems are most conveniently cast in terms of polar coordinates. To this end, first the governing differential equations discussed in Chapter 1 are expressed in terms of polar coordinates. Then a number of important problems involving polar coordinates are solved.



## 4.1 Cylindrical and Polar Coordinates

### 4.1.1 Geometrical Axisymmetry

A large number of practical engineering problems involve geometrical features which have a natural **axis of symmetry**, such as the solid cylinder, shown in Fig. 4.1.1. The axis of symmetry is an **axis of revolution**; the feature which possesses **axisymmetry** (axial symmetry) can be generated by revolving a surface (or line) about this axis.

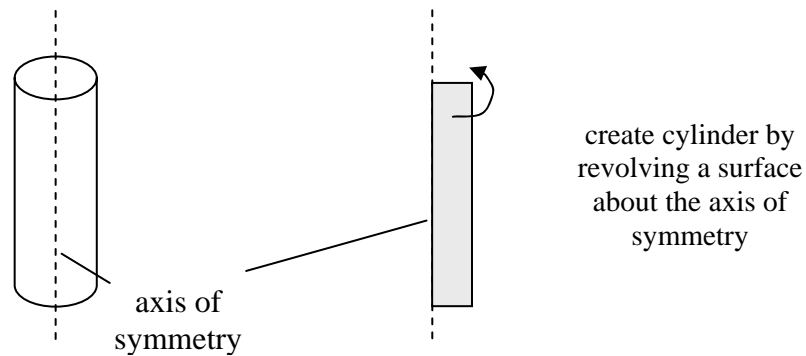

**Figure 4.1.1: a cylinder**

Some other axisymmetric geometries are illustrated Fig. 4.1.2; a frustum, a disk on a shaft and a sphere.

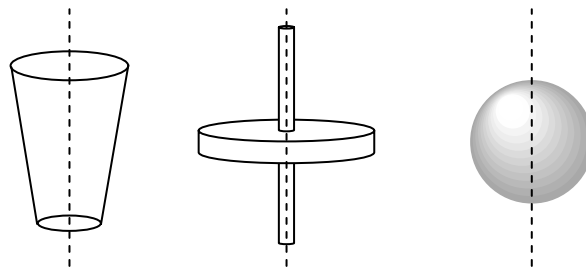

**Figure 4.1.2: axisymmetric geometries**

Some features are not only axisymmetric – they can be represented by a plane, which is similar to other planes right through the axis of symmetry. The hollow cylinder shown in Fig. 4.1.3 is an example of this **plane axisymmetry**.

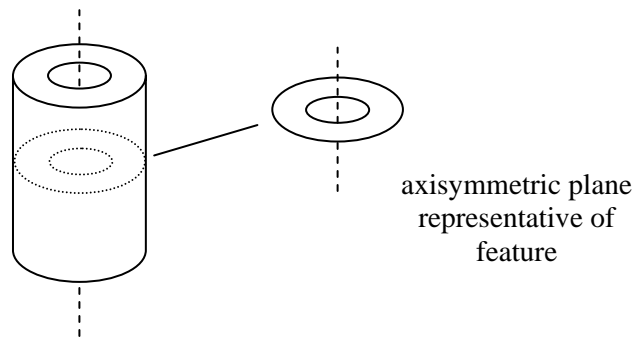

**Figure 4.1.3: a plane axisymmetric geometries**

### **Axially Non-Symmetric Geometries**

**Axially non-symmetric** geometries are ones which have a natural axis associated with them, but which are not completely symmetric. Some examples of this type of feature, the curved beam and the half-space, are shown in Fig. 4.1.4; the half-space extends to “infinity” in the axial direction and in the radial direction “below” the surface – it can be thought of as a solid half-cylinder of infinite radius. One can also have plane axially non-symmetric features; in fact, both of these are examples of such features; a slice through the objects perpendicular to the axis of symmetry will be representative of the whole object.

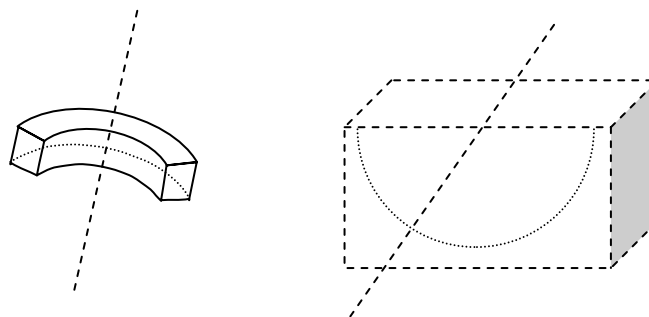

**Figure 4.1.4: a plane axisymmetric geometries**

## **4.1.2 Cylindrical and Polar Coordinates**

The above features are best described using **cylindrical coordinates**, and the plane versions can be described using **polar coordinates**. These coordinates systems are described next.

### **Stresses and Strains in Cylindrical Coordinates**

Using cylindrical coordinates, any point on a feature will have specific  $(r, \theta, z)$  coordinates, Fig. 4.1.5:

- $r$  – the **radial** direction (“out” from the axis)
- $\theta$  – the **circumferential** or **tangential** direction (“around” the axis – counterclockwise when viewed from the positive  $z$  side of the  $z = 0$  plane)
- $z$  – the **axial** direction (“along” the axis)

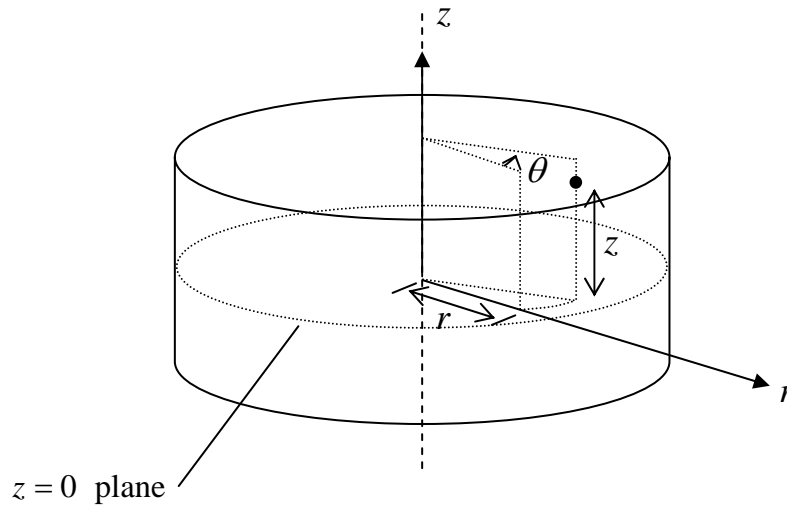
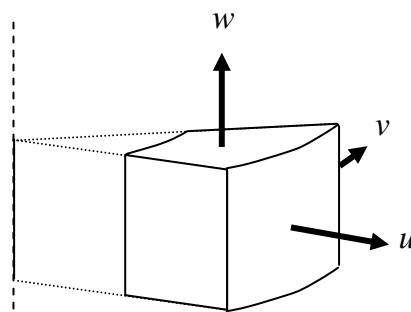

**Figure 4.1.5: cylindrical coordinates**

The displacement of a material point can be described by the three components in the radial, tangential and axial directions. These are often denoted by

$$u \equiv u_r, v \equiv u_\theta \text{ and } w \equiv u_z$$

respectively; they are shown in Fig. 4.1.6. Note that the displacement  $v$  is positive in the positive  $\theta$  direction, i.e. the direction of increasing  $\theta$ .



**Figure 4.1.6: displacements in cylindrical coordinates**

The stresses acting on a small element of material in the cylindrical coordinate system are as shown in Fig. 4.1.7 (the normal stresses on the left, the shear stresses on the right).

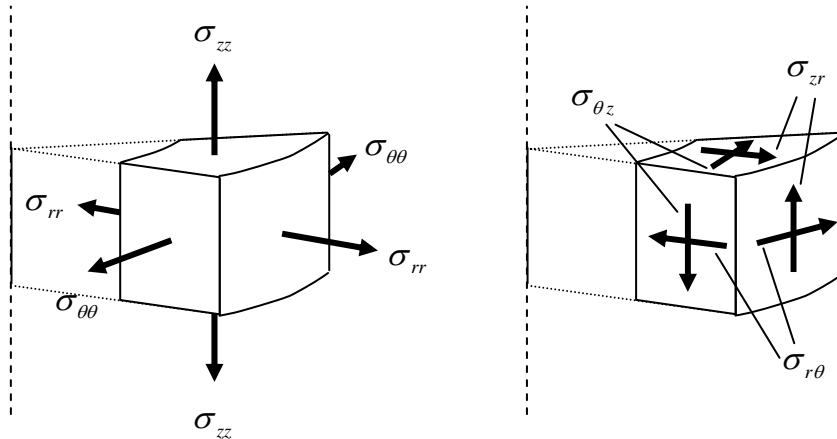

**Figure 4.1.7: stresses in cylindrical coordinates**

The normal strains  $\epsilon_{rr}$ ,  $\epsilon_{\theta\theta}$  and  $\epsilon_{zz}$  are a measure of the elongation/shortening of material, per unit length, in the radial, tangential and axial directions respectively; the shear strains  $\epsilon_{r\theta}$ ,  $\epsilon_{\theta z}$  and  $\epsilon_{zr}$  represent (half) the change in the right angles between line elements along the coordinate directions. The physical meaning of these strains is illustrated in Fig. 4.1.8.

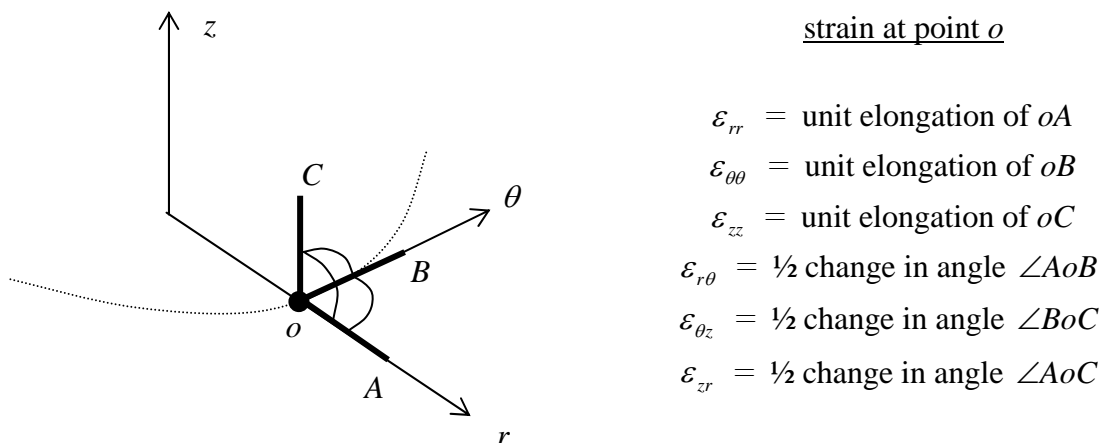

**Figure 4.1.8: strains in cylindrical coordinates**

### Plane Problems and Polar Coordinates

The stresses in any particular plane of an axisymmetric body can be described using the two-dimensional polar coordinates  $(r, \theta)$  shown in Fig. 4.1.9.

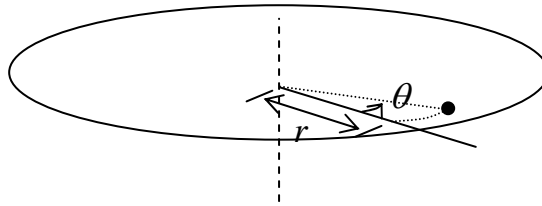

**Figure 4.1.9: polar coordinates**

There are *three* stress components acting *in* the plane  $z = 0$ : the radial stress  $\sigma_{rr}$ , the circumferential (tangential) stress  $\sigma_{\theta\theta}$  and the shear stress  $\sigma_{r\theta}$ , as shown in Fig. 4.1.10. Note the direction of the (positive) shear stress – it is conventional to take the  $z$  axis out of the page and so the  $\theta$  direction is counterclockwise. The three stress components which do not act in this plane, but which act *on* this plane ( $\sigma_{zz}$ ,  $\sigma_{\theta z}$  and  $\sigma_{zr}$ ), may or may not be zero, depending on the particular problem (see later).

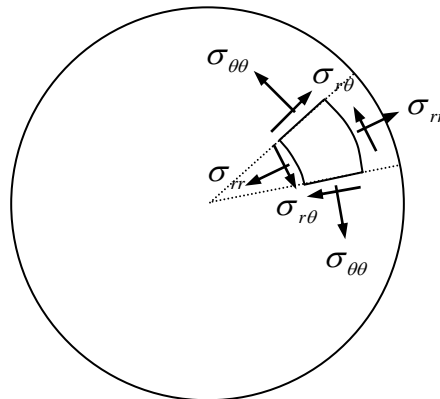

**Figure 4.1.10: stresses in polar coordinates**

## 4.2 Differential Equations in Polar Coordinates

Here, the two-dimensional Cartesian relations of Chapter 1 are re-cast in polar coordinates.

### 4.2.1 Equilibrium equations in Polar Coordinates

One way of expressing the equations of equilibrium in polar coordinates is to apply a change of coordinates directly to the 2D Cartesian version, Eqns. 1.1.8, as outlined in the Appendix to this section, §4.2.6. Alternatively, the equations can be derived from first principles by considering an element of material subjected to stresses  $\sigma_{rr}$ ,  $\sigma_{\theta\theta}$  and  $\sigma_{r\theta}$ , as shown in Fig. 4.2.1. The dimensions of the element are  $\Delta r$  in the radial direction, and  $r\Delta\theta$  (inner surface) and  $(r + \Delta r)\Delta\theta$  (outer surface) in the tangential direction.

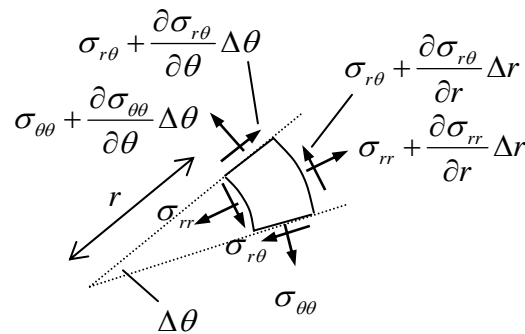

**Figure 4.2.1: an element of material**

Summing the forces in the radial direction leads to

$$\begin{aligned} \sum F_r = & \left( \sigma_{rr} + \frac{\partial \sigma_{rr}}{\partial r} \Delta r \right) (r + \Delta r) \Delta \theta - \sigma_{rr} r \Delta \theta \\ & - \sin \frac{\Delta \theta}{2} \left( \sigma_{\theta\theta} + \frac{\partial \sigma_{\theta\theta}}{\partial \theta} \Delta \theta \right) \Delta r - \sin \frac{\Delta \theta}{2} (\sigma_{\theta\theta}) \Delta r \\ & + \cos \frac{\Delta \theta}{2} \left( \sigma_{r\theta} + \frac{\partial \sigma_{r\theta}}{\partial \theta} \Delta \theta \right) \Delta r - \cos \frac{\Delta \theta}{2} (\sigma_{r\theta}) \Delta r \equiv 0 \end{aligned} \quad (4.2.1)$$

For a small element,  $\sin \theta \approx \theta$ ,  $\cos \theta \approx 1$  and so, dividing through by  $\Delta r \Delta \theta$ ,

$$\frac{\partial \sigma_{rr}}{\partial r} (r + \Delta r) + \sigma_{rr} - \sigma_{\theta\theta} - \frac{\Delta \theta}{2} \left( \frac{\partial \sigma_{\theta\theta}}{\partial \theta} \right) + \frac{\partial \sigma_{r\theta}}{\partial \theta} \equiv 0 \quad (4.2.2)$$

A similar calculation can be carried out for forces in the tangential direction {▲ Problem 1}. In the limit as  $\Delta r, \Delta \theta \rightarrow 0$ , one then has the two-dimensional equilibrium equations in polar coordinates:



$$\boxed{\begin{aligned} \frac{\partial \sigma_{rr}}{\partial r} + \frac{1}{r} \frac{\partial \sigma_{r\theta}}{\partial \theta} + \frac{1}{r} (\sigma_{rr} - \sigma_{\theta\theta}) &= 0 \\ \frac{\partial \sigma_{r\theta}}{\partial r} + \frac{1}{r} \frac{\partial \sigma_{\theta\theta}}{\partial \theta} + \frac{2\sigma_{r\theta}}{r} &= 0 \end{aligned}}$$

**Equilibrium Equations** (4.2.3)

## 4.2.2 Strain Displacement Relations and Hooke's Law

The two-dimensional strain-displacement relations can be derived from first principles by considering line elements initially lying in the  $r$  and  $\theta$  directions. Alternatively, as detailed in the Appendix to this section, §4.2.6, they can be derived directly from the Cartesian version, Eqns. 1.2.5,

$$\boxed{\begin{aligned} \varepsilon_{rr} &= \frac{\partial u_r}{\partial r} \\ \varepsilon_{\theta\theta} &= \frac{1}{r} \frac{\partial u_\theta}{\partial \theta} + \frac{u_r}{r} \\ \varepsilon_{r\theta} &= \frac{1}{2} \left( \frac{1}{r} \frac{\partial u_r}{\partial \theta} + \frac{\partial u_\theta}{\partial r} - \frac{u_\theta}{r} \right) \end{aligned}}$$

**2-D Strain-Displacement Expressions** (4.2.4)

The stress-strain relations in polar coordinates are completely analogous to those in Cartesian coordinates – the axes through a small material element are simply labelled with different letters. Thus Hooke's law is now

$$\begin{aligned} \varepsilon_{rr} &= \frac{1}{E} [\sigma_{rr} - \nu \sigma_{\theta\theta}], & \varepsilon_{\theta\theta} &= \frac{1}{E} [\sigma_{\theta\theta} - \nu \sigma_{rr}], & \varepsilon_{r\theta} &= \frac{1+\nu}{E} \sigma_{r\theta} \\ \varepsilon_{zz} &= -\frac{\nu}{E} (\sigma_{rr} + \sigma_{\theta\theta}) \end{aligned}$$

**Hooke's Law (Plane Stress)** (4.2.5a)

$$\varepsilon_{rr} = \frac{1+\nu}{E} [(1-\nu)\sigma_{rr} - \nu\sigma_{\theta\theta}], \quad \varepsilon_{\theta\theta} = \frac{1+\nu}{E} [-\nu\sigma_{rr} + (1-\nu)\sigma_{\theta\theta}], \quad \varepsilon_{r\theta} = \frac{1+\nu}{E} \sigma_{r\theta}$$

**Hooke's Law (Plane Strain)** (4.2.5b)

## 4.2.3 Stress Function Relations

In order to solve problems in polar coordinates using the stress function method, Eqns. 3.2.1 relating the stress components to the Airy stress function can be transformed using the relations in the Appendix to this section, §4.2.6:

$$\sigma_{rr} = \frac{1}{r} \frac{\partial \phi}{\partial r} + \frac{1}{r^2} \frac{\partial^2 \phi}{\partial \theta^2}, \quad \sigma_{\theta\theta} = \frac{\partial^2 \phi}{\partial r^2}, \quad \sigma_{r\theta} = -\frac{\partial}{\partial r} \left( \frac{1}{r} \frac{\partial \phi}{\partial \theta} \right) = \frac{1}{r^2} \frac{\partial \phi}{\partial \theta} - \frac{1}{r} \frac{\partial^2 \phi}{\partial r \partial \theta} \quad (4.2.6)$$

It can be verified that these equations automatically satisfy the equilibrium equations 4.2.3 {▲ Problem 2}.

The biharmonic equation 3.2.3 becomes

$$\left( \frac{\partial^2}{\partial r^2} + \frac{1}{r} \frac{\partial}{\partial r} + \frac{1}{r^2} \frac{\partial^2}{\partial \theta^2} \right)^2 \phi = 0 \quad (4.2.7)$$

#### 4.2.4 The Compatibility Relation

The compatibility relation expressed in polar coordinates is (see the Appendix to this section, §4.2.6)

$$\frac{1}{r^2} \frac{\partial^2 \varepsilon_{rr}}{\partial \theta^2} + \frac{\partial^2 \varepsilon_{\theta\theta}}{\partial r^2} - \frac{2}{r} \frac{\partial^2 \varepsilon_{r\theta}}{\partial r \partial \theta} - \frac{1}{r} \frac{\partial \varepsilon_{rr}}{\partial r} + \frac{2}{r} \frac{\partial \varepsilon_{\theta\theta}}{\partial r} - \frac{2}{r^2} \frac{\partial \varepsilon_{r\theta}}{\partial \theta} = 0 \quad (4.2.8)$$

#### 4.2.5 Problems

1. Derive the equilibrium equation 4.2.3b
2. Verify that the stress function relations 4.2.6 satisfy the equilibrium equations 4.2.3.
3. Verify that the strains as given by 4.2.4 satisfy the compatibility relations 4.2.8.

#### 4.2.6 Appendix to §4.2

##### From Cartesian Coordinates to Polar Coordinates

To transform equations from Cartesian to polar coordinates, first note the relations

$$\begin{aligned} x &= r \cos \theta, & y &= r \sin \theta \\ r &= \sqrt{x^2 + y^2}, & \theta &= \arctan(y/x) \end{aligned} \quad (4.2.9)$$

Then the Cartesian partial derivatives become

$$\begin{aligned} \frac{\partial}{\partial x} &= \frac{\partial r}{\partial x} \frac{\partial}{\partial r} + \frac{\partial \theta}{\partial x} \frac{\partial}{\partial \theta} = \cos \theta \frac{\partial}{\partial r} - \frac{\sin \theta}{r} \frac{\partial}{\partial \theta} \\ \frac{\partial}{\partial y} &= \frac{\partial r}{\partial y} \frac{\partial}{\partial r} + \frac{\partial \theta}{\partial y} \frac{\partial}{\partial \theta} = \sin \theta \frac{\partial}{\partial r} + \frac{\cos \theta}{r} \frac{\partial}{\partial \theta} \end{aligned} \quad (4.2.10)$$

The second partial derivatives are then

$$\begin{aligned}
\frac{\partial^2}{\partial x^2} &= \left( \cos \theta \frac{\partial}{\partial r} - \frac{\sin \theta}{r} \frac{\partial}{\partial \theta} \right) \left( \cos \theta \frac{\partial}{\partial r} - \frac{\sin \theta}{r} \frac{\partial}{\partial \theta} \right) \\
&= \cos \theta \frac{\partial}{\partial r} \left( \cos \theta \frac{\partial}{\partial r} \right) - \cos \theta \frac{\partial}{\partial r} \left( \frac{\sin \theta}{r} \frac{\partial}{\partial \theta} \right) - \frac{\sin \theta}{r} \frac{\partial}{\partial \theta} \left( \cos \theta \frac{\partial}{\partial r} \right) + \frac{\sin \theta}{r} \frac{\partial}{\partial \theta} \left( \frac{\sin \theta}{r} \frac{\partial}{\partial \theta} \right) \\
&= \cos^2 \theta \frac{\partial^2}{\partial r^2} + \sin^2 \theta \left( \frac{1}{r} \frac{\partial}{\partial r} + \frac{1}{r^2} \frac{\partial^2}{\partial \theta^2} \right) + \sin 2\theta \left( \frac{1}{r^2} \frac{\partial}{\partial \theta} - \frac{1}{r} \frac{\partial^2}{\partial r \partial \theta} \right)
\end{aligned} \tag{4.2.11}$$

Similarly,

$$\begin{aligned}
\frac{\partial^2}{\partial y^2} &= \sin^2 \theta \frac{\partial^2}{\partial r^2} + \cos^2 \theta \left( \frac{1}{r} \frac{\partial}{\partial r} + \frac{1}{r^2} \frac{\partial^2}{\partial \theta^2} \right) - \sin 2\theta \left( \frac{1}{r^2} \frac{\partial}{\partial \theta} - \frac{1}{r} \frac{\partial^2}{\partial r \partial \theta} \right) \\
\frac{\partial^2}{\partial x \partial y} &= -\sin \theta \cos \theta \left( -\frac{\partial^2}{\partial r^2} + \frac{1}{r} \frac{\partial}{\partial r} + \frac{1}{r^2} \frac{\partial^2}{\partial \theta^2} \right) - \cos 2\theta \left( \frac{1}{r^2} \frac{\partial}{\partial \theta} - \frac{1}{r} \frac{\partial^2}{\partial r \partial \theta} \right)
\end{aligned} \tag{4.2.12}$$

## Equilibrium Equations

The Cartesian stress components can be expressed in terms of polar components using the stress transformation formulae, Part I, Eqns. 3.4.7. Using a *negative* rotation (see Fig. 4.2.2), one has

$$\begin{aligned}
\sigma_{xx} &= \sigma_{rr} \cos^2 \theta + \sigma_{\theta\theta} \sin^2 \theta - \sigma_{r\theta} \sin 2\theta \\
\sigma_{yy} &= \sigma_{rr} \sin^2 \theta + \sigma_{\theta\theta} \cos^2 \theta + \sigma_{r\theta} \sin 2\theta \\
\sigma_{xy} &= \sin \theta \cos \theta (\sigma_{rr} - \sigma_{\theta\theta}) + \sigma_{r\theta} \cos 2\theta
\end{aligned} \tag{4.2.13}$$

Applying these and 4.2.10 to the 2D Cartesian equilibrium equations 3.1.3a-b lead to

$$\begin{aligned}
\cos \theta \left[ \frac{\partial \sigma_{rr}}{\partial r} + \frac{1}{r} \frac{\partial \sigma_{r\theta}}{\partial \theta} + \frac{1}{r} (\sigma_{rr} - \sigma_{\theta\theta}) \right] - \sin \theta \left[ \frac{\partial \sigma_{r\theta}}{\partial r} + \frac{1}{r} \frac{\partial \sigma_{\theta\theta}}{\partial \theta} + \frac{2\sigma_{r\theta}}{r} \right] &= 0 \\
\sin \theta \left[ \frac{\partial \sigma_{rr}}{\partial r} + \frac{1}{r} \frac{\partial \sigma_{r\theta}}{\partial \theta} + \frac{1}{r} (\sigma_{rr} - \sigma_{\theta\theta}) \right] + \cos \theta \left[ \frac{\partial \sigma_{r\theta}}{\partial r} + \frac{1}{r} \frac{\partial \sigma_{\theta\theta}}{\partial \theta} + \frac{2\sigma_{r\theta}}{r} \right] &= 0
\end{aligned} \tag{4.2.14}$$

which then give Eqns. 4.2.3.

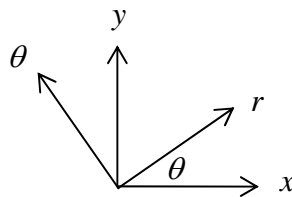

**Figure 4.2.2: rotation of axes**

## The Strain-Displacement Relations

Noting that

$$\begin{aligned} u_x &= u_r \cos \theta - u_\theta \sin \theta \\ u_y &= u_r \sin \theta + u_\theta \cos \theta \end{aligned} \quad (4.2.15)$$

the strains in polar coordinates can be obtained directly from Eqns. 1.2.5:

$$\begin{aligned} \varepsilon_{xx} &= \frac{\partial u_x}{\partial x} \\ &= \left( \cos \theta \frac{\partial}{\partial r} - \frac{\sin \theta}{r} \frac{\partial}{\partial \theta} \right) (u_r \cos \theta - u_\theta \sin \theta) \\ &= \cos^2 \theta \frac{\partial u_r}{\partial r} + \sin^2 \theta \left( \frac{1}{r} \frac{\partial u_\theta}{\partial \theta} + \frac{u_r}{r} \right) - \sin 2\theta \frac{1}{2} \left( \frac{1}{r} \frac{\partial u_r}{\partial \theta} + \frac{\partial u_\theta}{\partial r} - \frac{u_\theta}{r} \right) \end{aligned} \quad (4.2.16)$$

One obtains similar expressions for the strains  $\varepsilon_{yy}$  and  $\varepsilon_{xy}$ . Substituting the results into the strain transformation equations Part I, Eqns. 3.8.1,

$$\begin{aligned} \varepsilon_{rr} &= \varepsilon_{xx} \cos^2 \theta + \varepsilon_{yy} \sin^2 \theta + \varepsilon_{xy} \sin 2\theta \\ \varepsilon_{\theta\theta} &= \varepsilon_{xx} \sin^2 \theta + \varepsilon_{yy} \cos^2 \theta - \varepsilon_{xy} \sin 2\theta \\ \varepsilon_{r\theta} &= \sin \theta \cos \theta (\varepsilon_{yy} - \varepsilon_{xx}) + \varepsilon_{xy} \cos 2\theta \end{aligned} \quad (4.2.17)$$

then leads to the equations given above, Eqns. 4.2.4.

## The Stress – Stress Function Relations

The stresses in polar coordinates are related to the stresses in Cartesian coordinates through the stress transformation equations (this time a positive rotation; compare with Eqns. 4.2.13 and Fig. 4.2.2)

$$\begin{aligned} \sigma_{rr} &= \sigma_{xx} \cos^2 \theta + \sigma_{yy} \sin^2 \theta + \sigma_{xy} \sin 2\theta \\ \sigma_{\theta\theta} &= \sigma_{xx} \sin^2 \theta + \sigma_{yy} \cos^2 \theta - \sigma_{xy} \sin 2\theta \\ \sigma_{r\theta} &= \sin \theta \cos \theta (\sigma_{yy} - \sigma_{xx}) + \sigma_{xy} \cos 2\theta \end{aligned} \quad (4.2.18)$$

Using the Cartesian stress – stress function relations 3.2.1, one has

$$\sigma_{rr} = \frac{\partial^2 \phi}{\partial y^2} \cos^2 \theta + \frac{\partial^2 \phi}{\partial x^2} \sin^2 \theta - \frac{\partial^2 \phi}{\partial x \partial y} \sin 2\theta \quad (4.2.19)$$

and similarly for  $\sigma_{\theta\theta}$ ,  $\sigma_{r\theta}$ . Using 4.2.11-12 then leads to 4.2.6.

### The Compatibility Relation

Beginning with the Cartesian relation 1.3.1, each term can be transformed using 4.2.11-12 and the strain transformation relations, for example

$$\frac{\partial^2 \varepsilon_{xx}}{\partial x^2} = \left( \cos^2 \theta \frac{\partial^2}{\partial r^2} + \sin^2 \theta \left( \frac{1}{r} \frac{\partial}{\partial r} + \frac{1}{r^2} \frac{\partial^2}{\partial \theta^2} \right) + \sin 2\theta \left( \frac{1}{r^2} \frac{\partial}{\partial \theta} - \frac{1}{r} \frac{\partial^2}{\partial r \partial \theta} \right) \right) \times \quad (4.2.20)$$

$$\left( \varepsilon_{rr} \cos^2 \theta + \varepsilon_{\theta\theta} \sin^2 \theta - \varepsilon_{r\theta} \sin 2\theta \right)$$

After some lengthy calculations, one arrives at 4.2.8.

## 4.3 Plane Axisymmetric Problems

In this section are considered **plane axisymmetric problems**. These are problems in which both the geometry *and* loading are axisymmetric.

### 4.3.1 Plane Axisymmetric Problems

Some three dimensional (not necessarily plane) examples of axisymmetric problems would be the thick-walled (hollow) cylinder under internal pressure, a disk rotating about its axis<sup>1</sup>, and the two examples shown in Fig. 4.3.1; the first is a complex component loaded in a complex way, but exhibits axisymmetry in both geometry and loading; the second is a sphere loaded by concentrated forces along a diameter.

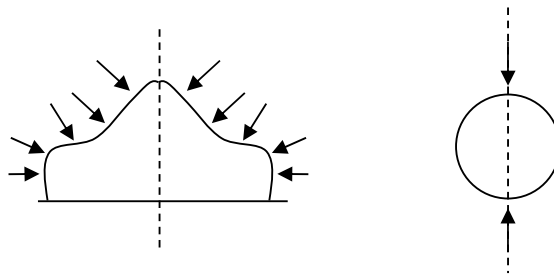

**Figure 4.3.1: axisymmetric problems**

A two-dimensional (plane) example would be one plane of the thick-walled cylinder under internal pressure, illustrated in Fig. 4.3.2<sup>2</sup>.

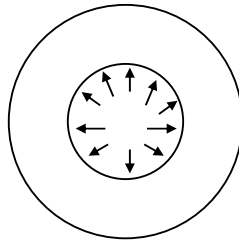
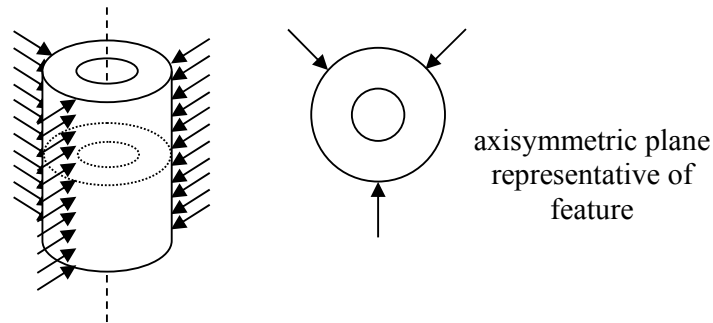

**Figure 4.3.2: a cross section of an internally pressurised cylinder**

It should be noted that many problems involve axisymmetric geometries but non-axisymmetric loadings, and *vice versa*. These problems are *not* axisymmetric. An example is shown in Fig. 4.3.3 (the problem involves a plane axisymmetric geometry).

<sup>1</sup> the rotation induces a stress in the disk

<sup>2</sup> the rest of the cylinder is coming out of, and into, the page



**Figure 4.3.3: An axially symmetric geometry but with a non-axisymmetric loading**

The important characteristic of these axisymmetric problems is that all quantities, be they stress, displacement, strain, or anything else associated with the problem, *must be independent of the circumferential variable  $\theta$* . As a consequence, any term in the differential equations of §4.2 involving the derivatives  $\partial/\partial\theta$ ,  $\partial^2/\partial\theta^2$ , etc. can be immediately set to zero.

### 4.3.2 Governing Equations for Plane Axisymmetric Problems

The two-dimensional strain-displacement relations are given by Eqns. 4.2.4 and these simplify in the axisymmetric case to

$$\begin{aligned}\varepsilon_{rr} &= \frac{\partial u_r}{\partial r} \\ \varepsilon_{\theta\theta} &= \frac{u_r}{r} \\ \varepsilon_{r\theta} &= \frac{1}{2} \left( \frac{\partial u_\theta}{\partial r} - \frac{u_\theta}{r} \right)\end{aligned}\tag{4.3.1}$$

Here, it will be assumed that the displacement  $u_\theta = 0$ . Cases where  $u_\theta \neq 0$  but where the stresses and strains are still independent of  $\theta$  are termed **quasi-axisymmetric problems**; these will be examined in a later section. Then 4.3.1 reduces to

$$\boxed{\varepsilon_{rr} = \frac{\partial u_r}{\partial r}, \quad \varepsilon_{\theta\theta} = \frac{u_r}{r}, \quad \varepsilon_{r\theta} = 0}\tag{4.3.2}$$

It follows from Hooke's law that  $\sigma_{r\theta} = 0$ . The non-zero stresses are illustrated in Fig. 4.3.4.

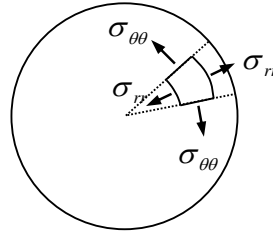

**Figure 4.3.4: stress components in plane axisymmetric problems**

### 4.3.3 Plane Stress and Plane Strain

Two cases arise with plane axisymmetric problems: in the plane stress problem, the feature is very thin and unloaded on its larger free-surfaces, for example a thin disk under external pressure, as shown in Fig. 4.3.5. Only two stress components remain, and Hooke's law 4.2.5a reads

$$\begin{aligned} \varepsilon_{rr} &= \frac{1}{E} [\sigma_{rr} - \nu \sigma_{\theta\theta}] & \sigma_{rr} &= \frac{E}{1-\nu^2} [\varepsilon_{rr} + \nu \varepsilon_{\theta\theta}] \\ \varepsilon_{\theta\theta} &= \frac{1}{E} [\sigma_{\theta\theta} - \nu \sigma_{rr}] & \sigma_{\theta\theta} &= \frac{E}{1-\nu^2} [\varepsilon_{\theta\theta} + \nu \varepsilon_{rr}] \end{aligned} \quad (4.3.3)$$

with  $\varepsilon_{zz} = \frac{-\nu}{E} (\sigma_{rr} + \sigma_{\theta\theta})$ ,  $\varepsilon_{zr} = \varepsilon_{z\theta} = 0$  and  $\sigma_{zz} = 0$ .

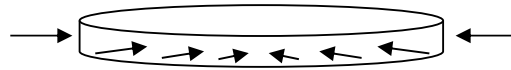

**Figure 4.3.5: plane stress axisymmetric problem**

In the plane strain case, the strains  $\varepsilon_{zz}$ ,  $\varepsilon_{z\theta}$  and  $\varepsilon_{zr}$  are zero. This will occur, for example, in a hollow cylinder under internal pressure, with the ends fixed between immovable platens, Fig. 4.3.6.

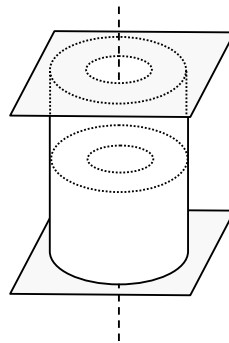

**Figure 4.3.6: plane strain axisymmetric problem**



Hooke's law 4.2.5b reads

$$\begin{aligned} \varepsilon_{rr} &= \frac{1+\nu}{E} [(1-\nu)\sigma_{rr} - \nu\sigma_{\theta\theta}] & \text{or} & & \sigma_{rr} &= \frac{E}{(1+\nu)(1-2\nu)} [\nu\varepsilon_{\theta\theta} + (1-\nu)\varepsilon_{rr}] \\ \varepsilon_{\theta\theta} &= \frac{1+\nu}{E} [(1-\nu)\sigma_{\theta\theta} - \nu\sigma_{rr}] & & & \sigma_{\theta\theta} &= \frac{E}{(1+\nu)(1-2\nu)} [\nu\varepsilon_{rr} + (1-\nu)\varepsilon_{\theta\theta}] \end{aligned} \quad (4.3.4)$$

with  $\sigma_{zz} = \nu(\sigma_{rr} + \sigma_{\theta\theta})$ .

Shown in Fig. 4.3.7 are the stresses acting in the axisymmetric plane body (with  $\sigma_{zz}$  zero in the plane stress case).

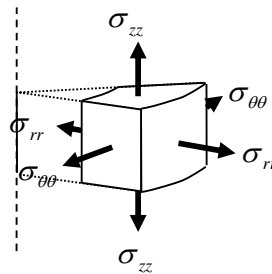

**Figure 4.3.7: stress components in plane axisymmetric problems**

### 4.3.4 Solution of Plane Axisymmetric Problems

The equations governing the plane axisymmetric problem are the equations of equilibrium 4.2.3 which reduce to the single equation

$$\boxed{\frac{\partial \sigma_{rr}}{\partial r} + \frac{1}{r}(\sigma_{rr} - \sigma_{\theta\theta}) = 0}, \quad (4.3.5)$$

the strain-displacement relations 4.3.2 and the stress-strain law 4.3.3-4.

Taking the plane stress case, substituting 4.3.2 into the second of 4.3.3 and then substituting the result into 4.3.5 leads to (with a similar result for plane strain)

$$\frac{d^2 u}{dr^2} + \frac{1}{r} \frac{du}{dr} - \frac{1}{r^2} u = 0 \quad (4.3.6)$$

This is Navier's equation for plane axisymmetry. It is an "Euler-type" ordinary differential equation which can be solved exactly to get (see Appendix to this section, §4.3.8)

$$u = C_1 r + C_2 \frac{1}{r} \quad (4.3.7)$$

With the displacement known, the stresses and strains can be evaluated, and the full solution is

$$\begin{aligned}
 u &= C_1 r + C_2 \frac{1}{r} \\
 \varepsilon_{rr} &= C_1 - C_2 \frac{1}{r^2}, \quad \varepsilon_{\theta\theta} = C_1 + C_2 \frac{1}{r^2} \\
 \sigma_{rr} &= \frac{E}{1-\nu} C_1 - \frac{E}{1+\nu} C_2 \frac{1}{r^2}, \quad \sigma_{\theta\theta} = \frac{E}{1-\nu} C_1 + \frac{E}{1+\nu} C_2 \frac{1}{r^2}
 \end{aligned} \tag{4.3.8}$$

For problems involving stress boundary conditions, it is best to have simpler expressions for the stress so, introducing new constants  $A = -EC_2 / (1 + \nu)$  and  $C = EC_1 / 2(1 - \nu)$ , the solution can be re-written as

$$\begin{aligned}
 \sigma_{rr} &= +A \frac{1}{r^2} + 2C, \quad \sigma_{\theta\theta} = -A \frac{1}{r^2} + 2C \\
 \varepsilon_{rr} &= +\frac{(1+\nu)A}{E} \frac{1}{r^2} + \frac{2(1-\nu)C}{E}, \quad \varepsilon_{\theta\theta} = -\frac{(1+\nu)A}{E} \frac{1}{r^2} + \frac{2(1-\nu)C}{E}, \quad \varepsilon_{zz} = -\frac{4\nu C}{E} \\
 u &= -\frac{(1+\nu)A}{E} \frac{1}{r} + \frac{2(1-\nu)C}{E} r
 \end{aligned} \tag{4.3.9}$$

**Plane stress axisymmetric solution**

Similarly, the plane strain solution turns out to be again 4.3.8a-b only the stresses are now {▲ Problem 1}

$$\sigma_{rr} = \frac{E}{(1+\nu)(1-2\nu)} \left[ -(1-2\nu)C_2 \frac{1}{r^2} + C_1 \right], \quad \sigma_{\theta\theta} = \frac{E}{(1+\nu)(1-2\nu)} \left[ +(1-2\nu)C_2 \frac{1}{r^2} + C_1 \right] \tag{4.3.10}$$

Then, with  $A = -EC_2 / (1 + \nu)$  and  $C = EC_1 / 2(1 + \nu)(1 - 2\nu)$ , the solution can be written as

$$\begin{aligned}
 \sigma_{rr} &= +A \frac{1}{r^2} + 2C, \quad \sigma_{\theta\theta} = -A \frac{1}{r^2} + 2C, \quad \sigma_{zz} = 4\nu C \\
 \varepsilon_{rr} &= \frac{1+\nu}{E} \left[ +A \frac{1}{r^2} + 2(1-2\nu)C \right], \quad \varepsilon_{\theta\theta} = \frac{1+\nu}{E} \left[ -A \frac{1}{r^2} + 2(1-2\nu)C \right] \\
 u &= \frac{1+\nu}{E} \left[ -A \frac{1}{r} + 2(1-2\nu)Cr \right]
 \end{aligned} \tag{4.3.11}$$

**Plane strain axisymmetric solution**

The solutions 4.3.9, 4.3.11 involve two constants. When there is a solid body with one boundary,  $A$  must be zero in order to ensure finite-valued stresses and strains;  $C$  can be determined from the boundary condition. When there are two boundaries, both  $A$  and  $C$  are determined from the boundary conditions.

### 4.3.5 Example: Expansion of a thick circular cylinder under internal pressure

Consider the problem of Fig. 4.3.8. The two unknown constants  $A$  and  $C$  are obtained from the boundary conditions

$$\begin{aligned}\sigma_{rr}(a) &= -p \\ \sigma_{rr}(b) &= 0\end{aligned}\quad (4.3.12)$$

which lead to

$$\sigma_{rr}(a) = \frac{A}{a^2} + 2C = -p, \quad \sigma_{rr}(b) = \frac{A}{b^2} + 2C = 0 \quad (4.3.13)$$

so that

$$\sigma_{rr} = -p \frac{b^2/r^2 - 1}{b^2/a^2 - 1}, \quad \sigma_{\theta\theta} = +p \frac{b^2/r^2 + 1}{b^2/a^2 - 1}, \quad \sigma_{zz} = \nu(\sigma_{rr} + \sigma_{\theta\theta}) \quad (4.3.14)$$

**Cylinder under Internal Pressure**

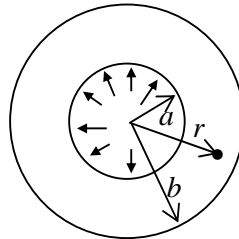

**Figure 4.3.8: an internally pressurised cylinder**

The stresses through the thickness of the cylinder walls are shown in Fig. 4.3.9a. The maximum principal stress is the  $\sigma_{\theta\theta}$  stress and this attains a maximum at the inner face. For this reason, internally pressurized vessels often fail there first, with microcracks perpendicular to the inner edge been driven by the tangential stress, as illustrated in Fig. 4.3.9b.

Note that by setting  $b = a + t$  and taking the wall thickness to be very small,  $t, t^2 \ll a$ , and letting  $a = r$ , the solution 4.3.14 reduces to:

$$\sigma_{rr} = -p, \quad \sigma_{\theta\theta} = +p \frac{r}{t}, \quad \sigma_{zz} = \nu p \frac{r}{t} \quad (4.3.15)$$

which is equivalent to the thin-walled pressure-vessel solution, Part I, §4.5.2 (if  $\nu = 1/2$ , i.e. incompressible).

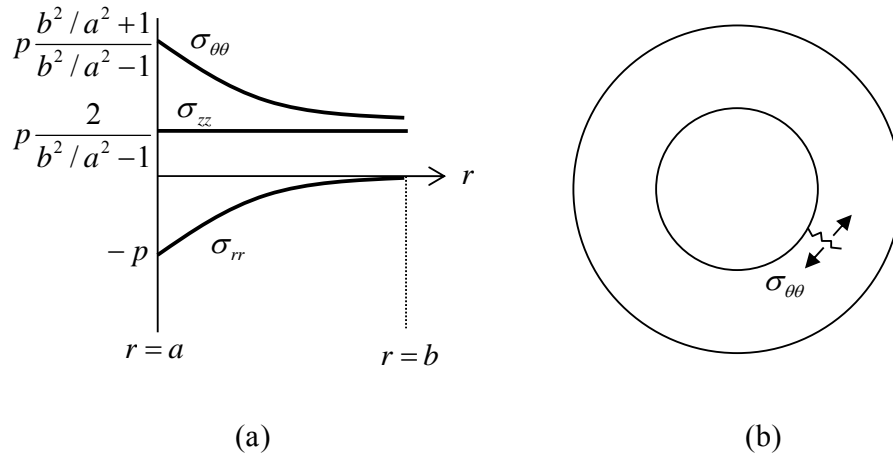

**Figure 4.3.9: (a) stresses in the thick-walled cylinder, (b) microcracks driven by tangential stress**

### Generalised Plane Strain and Other Solutions

The solution for a pressurized cylinder in plane strain was given above, i.e. where  $\varepsilon_{zz}$  was enforced to be zero. There are two other useful situations:

- (1) The cylinder is free to expand in the axial direction. In this case,  $\varepsilon_{zz}$  is not forced to zero, but allowed to be a constant along the length of the cylinder, say  $\bar{\varepsilon}_{zz}$ . The  $\sigma_{zz}$  stress is zero, as in plane stress. This situation is called **generalized plane strain**.
- (2) The cylinder is closed at its ends. Here, the axial stresses  $\sigma_{zz}$  inside the walls of the tube are counteracted by the internal pressure  $p$  acting on the closed ends. The force acting on the closed ends due to the pressure is  $p\pi a^2$  and the balancing axial force is  $\sigma_{zz}\pi(b^2 - a^2)$ , assuming  $\sigma_{zz}$  to be constant through the thickness. For equilibrium

$$\sigma_{zz} = \frac{p}{b^2/a^2 - 1} \quad (4.3.16)$$

Returning to the full three-dimensional stress-strain equations (Part I, Eqns. 6.1.9), set  $\varepsilon_{zz} = \bar{\varepsilon}_{zz}$ , a constant, and  $\varepsilon_{xz} = \varepsilon_{yz} = 0$ . Re-labelling  $x, y, z$  with  $r, \theta, z$ , and again with  $\sigma_{r\theta} = 0$ , one has

$$\begin{aligned} \sigma_{rr} &= \frac{E}{(1+\nu)(1-2\nu)} \left[ (1-\nu)\varepsilon_{rr} + \nu(\varepsilon_{\theta\theta} + \bar{\varepsilon}_{zz}) \right] \\ \sigma_{\theta\theta} &= \frac{E}{(1+\nu)(1-2\nu)} \left[ (1-\nu)\varepsilon_{\theta\theta} + \nu(\varepsilon_{rr} + \bar{\varepsilon}_{zz}) \right] \\ \sigma_{zz} &= \frac{E}{(1+\nu)(1-2\nu)} \left[ (1-\nu)\bar{\varepsilon}_{zz} + \nu(\varepsilon_{rr} + \varepsilon_{\theta\theta}) \right] \end{aligned} \quad (4.3.17)$$

Substituting the strain-displacement relations 4.3.2 into 4.3.16a-b, and, as before, using the axisymmetric equilibrium equation 4.3.5, again leads to the differential equation 4.3.6 and the solution  $u = C_1 r + C_2 / r$ , with  $\varepsilon_{rr} = C_1 - C_2 / r^2$ ,  $\varepsilon_{\theta\theta} = C_1 + C_2 / r^2$ , but now the stresses are

$$\begin{aligned}\sigma_{rr} &= \frac{E}{(1+\nu)(1-2\nu)} \left[ C_1 - (1-2\nu)C_2 \frac{1}{r^2} + \nu \bar{\varepsilon}_{zz} \right] \\ \sigma_{\theta\theta} &= \frac{E}{(1+\nu)(1-2\nu)} \left[ C_1 + (1-2\nu)C_2 \frac{1}{r^2} + \nu \bar{\varepsilon}_{zz} \right] \\ \sigma_{zz} &= \frac{E}{(1+\nu)(1-2\nu)} \left[ 2\nu C_1 + (1-\nu)\nu \bar{\varepsilon}_{zz} \right]\end{aligned}\quad (4.3.18)$$

As before, to make the solution more amenable to stress boundary conditions, we let  $A = -EC_2 / (1+\nu)$  and  $C = EC_1 / 2(1+\nu)(1-2\nu)$ , so that the solution is

$$\begin{aligned}\sigma_{rr} &= +A \frac{1}{r^2} + 2C + \frac{\nu E}{(1+\nu)(1-2\nu)} \bar{\varepsilon}_{zz}, & \sigma_{\theta\theta} &= -A \frac{1}{r^2} + 2C + \frac{\nu E}{(1+\nu)(1-2\nu)} \bar{\varepsilon}_{zz} \\ \sigma_{zz} &= 4\nu C + \frac{(1-\nu)E}{(1+\nu)(1-2\nu)} \bar{\varepsilon}_{zz} \\ \varepsilon_{rr} &= \frac{1+\nu}{E} \left[ +A \frac{1}{r^2} + 2(1-2\nu)C \right], & \varepsilon_{\theta\theta} &= \frac{1+\nu}{E} \left[ -A \frac{1}{r^2} + 2(1-2\nu)C \right] \\ u &= \frac{1+\nu}{E} \left[ -A \frac{1}{r} + 2(1-2\nu)Cr \right]\end{aligned}\quad (4.3.19)$$

**Generalised axisymmetric solution**

For internal pressure  $p$ , the solution to 4.3.19 gives the same solution for radial and tangential stresses as before, Eqn. 4.3.14. The axial displacement is  $u_z = z\bar{\varepsilon}_{zz}$  (to within a constant).

In the case of the cylinder with open ends (generalized plane strain),  $\sigma_{zz} = 0$ , and one finds from Eqn. 4.3.19 that  $\bar{\varepsilon}_{zz} = -2\nu p / E(b^2 / a^2 - 1) < 0$ . In the case of the cylinder with closed ends, one finds that  $\bar{\varepsilon}_{zz} = (1-2\nu)p / E(b^2 / a^2 - 1) > 0$ .

### A Transversely isotropic Cylinder

Consider now a transversely isotropic cylinder. The strain-displacement relations 4.3.2 and the equilibrium equation 4.3.5 are applicable to any type of material. The stress-strain law can be expressed as (see Part I, Eqn. 6.2.14)

$$\begin{aligned}\sigma_{rr} &= C_{11}\varepsilon_{rr} + C_{12}\varepsilon_{\theta\theta} + C_{13}\varepsilon_{zz} \\ \sigma_{\theta\theta} &= C_{12}\varepsilon_{rr} + C_{11}\varepsilon_{\theta\theta} + C_{13}\varepsilon_{zz} \\ \sigma_{zz} &= C_{13}\varepsilon_{rr} + C_{13}\varepsilon_{\theta\theta} + C_{33}\varepsilon_{zz}\end{aligned}\quad (4.3.20)$$

Here, take  $\varepsilon_{zz} = \bar{\varepsilon}_{zz}$ , a constant. Then, using the strain-displacement relations and the equilibrium equation, one again arrives at the differential equation 4.3.6 so the solution for displacement and strain is again 4.3.8a-b. With  $A = C_2 / (C_{12} - C_{11})$  and  $C = C_1 / 2(C_{11} + C_{12})$ , the stresses can be expressed as

$$\begin{aligned}\sigma_{rr} &= +A \frac{1}{r^2} + 2C + C_{13} \bar{\varepsilon}_{zz} \\ \sigma_{\theta\theta} &= -A \frac{1}{r^2} + 2C + C_{13} \bar{\varepsilon}_{zz} \\ \sigma_{zz} &= 4C \frac{C_{13}}{C_{11} + C_{12}} + C_{33} \bar{\varepsilon}_{zz}\end{aligned}\quad (4.3.21)$$

The plane strain solution then follows from  $\bar{\varepsilon}_{zz} = 0$  and the generalized plane strain solution from  $\sigma_{zz} = 0$ . These solutions reduce to 4.3.11, 4.3.19 in the isotropic case.

### 4.3.6 Stress Function Solution

An alternative solution procedure for axisymmetric problems is the stress function approach. To this end, first specialise equations 4.2.6 to the axisymmetric case:

$$\sigma_{rr} = \frac{1}{r} \frac{\partial \phi}{\partial r}, \quad \sigma_{\theta\theta} = \frac{\partial^2 \phi}{\partial r^2}, \quad \sigma_{r\theta} = 0 \quad (4.3.22)$$

One can check that these equations satisfy the axisymmetric equilibrium equation 4.3.4.

The biharmonic equation in polar coordinates is given by Eqn. 4.2.7. Specialising this to the axisymmetric case, that is, setting  $\partial / \partial \theta = 0$ , leads to

$$\left( \frac{\partial^2}{\partial r^2} + \frac{1}{r} \frac{\partial}{\partial r} \right)^2 \phi = \left( \frac{\partial^2}{\partial r^2} + \frac{1}{r} \frac{\partial}{\partial r} \right) \left( \frac{\partial^2 \phi}{\partial r^2} + \frac{1}{r} \frac{\partial \phi}{\partial r} \right) = 0 \quad (4.3.23)$$

or

$$\frac{d^4 \phi}{dr^4} + \frac{2}{r} \frac{d^3 \phi}{dr^3} - \frac{1}{r^2} \frac{d^2 \phi}{dr^2} + \frac{1}{r^3} \frac{d\phi}{dr} = 0 \quad (4.3.24)$$

Alternatively, one could have started with the compatibility relation 4.2.8, specialised that to the axisymmetric case:

$$\frac{\partial^2 \varepsilon_{\theta\theta}}{\partial r^2} - \frac{1}{r} \frac{\partial \varepsilon_{rr}}{\partial r} + \frac{2}{r} \frac{\partial \varepsilon_{\theta\theta}}{\partial r} = 0 \quad (4.3.25)$$

and then combine with Hooke's law 4.3.3 or 4.3.4, and 4.3.22, to again get 4.3.24.

Eqn. 4.3.24 is an Euler-type ODE and has solution (see Appendix to this section, §4.3.8)

$$\phi = A \ln r + Br^2 \ln r + Cr^2 + D \quad (4.3.26)$$

The stresses then follow from 4.3.22:

$$\begin{aligned} \sigma_{rr} &= +\frac{A}{r^2} + B(1 + 2 \ln r) + 2C \\ \sigma_{\theta\theta} &= -\frac{A}{r^2} + B(3 + 2 \ln r) + 2C \end{aligned} \quad (4.3.27)$$

The strains are obtained from the stress-strain relations. For plane strain, one has, from 4.3.4,

$$\begin{aligned} \varepsilon_{rr} &= \frac{1+\nu}{E} \left\{ +\frac{A}{r^2} + B[1 - 4\nu + 2(1 - 2\nu)\ln r] + 2C(1 - 2\nu) \right\} \\ \varepsilon_{\theta\theta} &= \frac{1+\nu}{E} \left\{ -\frac{A}{r^2} + B[3 - 4\nu + 2(1 - 2\nu)\ln r] + 2C(1 - 2\nu) \right\} \end{aligned} \quad (4.3.28)$$

Comparing these with the strain-displacement relations 4.3.2, and integrating  $\varepsilon_{rr}$ , one has

$$\begin{aligned} u_r &= \int \varepsilon_{rr} dr = \frac{1+\nu}{E} \left\{ -\frac{A}{r} + Br[-1 + 2(1 - 2\nu)\ln r] + 2C(1 - 2\nu)r \right\} + F \\ u_r = r\varepsilon_{\theta\theta} &= \frac{1+\nu}{E} \left\{ -\frac{A}{r} + Br[+1 + 2(1 - 2\nu)\ln r] + 2C(1 - 2\nu)r \right\} \end{aligned} \quad (4.3.27)$$

To ensure that one has a unique displacement  $u_r$ , one must have  $B = 0$  and the constant of integration  $F = 0$ , and so one again has the solution 4.3.11<sup>3</sup>.

### 4.3.7 Problems

1. Derive the solution equations 4.3.11 for axisymmetric plane strain.
2. A cylindrical rock specimen is subjected to a pressure  $p$  over its cylindrical face and is constrained in the axial direction. What are the stresses, including the axial stress, in the specimen? What are the displacements?

<sup>3</sup> the biharmonic equation was derived using the expression for compatibility of strains (4.3.23 being the axisymmetric version). In simply connected domains, i.e. bodies without holes, compatibility is assured (and indeed  $A$  and  $B$  must be zero in 4.3.26 to ensure finite strains). In multiply connected domains, however, for example the hollow cylinder, the compatibility condition is necessary but *not sufficient* to ensure compatible strains (see, for example, Shames and Cozzarelli (1997)), and this is why compatibility of strains must be explicitly enforced as in 4.3.25

3. A long hollow tube is subjected to internal pressure  $p_i$  and external pressures  $p_o$  and constrained in the axial direction. What is the stress state in the walls of the tube?  
What if  $p_i = p_o = p$ ?
4. A long mine tunnel of radius  $a$  is cut in deep rock. Before the mine is constructed the rock is under a uniform pressure  $p$ . Considering the rock to be an infinite, homogeneous elastic medium with elastic constants  $E$  and  $\nu$ , determine the radial displacement at the surface of the tunnel due to the excavation. What radial stress  $\sigma_{rr}(a) = -P$  should be applied to the wall of the tunnel to prevent any such displacement?
5. A long hollow elastic tube is fitted to an inner rigid (immovable) shaft. The tube is perfectly bonded to the shaft. An external pressure  $p$  is applied to the tube. What are the stresses and strains in the tube?
6. Repeat Problem 3 for the case when the tube is free to expand in the axial direction. How much does the tube expand in the axial direction (take  $u_z = 0$  at  $z = 0$ )?

### 4.3.8 Appendix

#### Solution to Eqn. 4.3.6

The differential equation 4.3.6 can be solved by a change of variable  $r = e^t$ , so that

$$r = e^t, \quad \log r = t, \quad \frac{1}{r} = \frac{dt}{dr} \quad (4.3.28)$$

and, using the chain rule,

$$\begin{aligned} \frac{du}{dr} &= \frac{du}{dt} \frac{dt}{dr} = \frac{1}{r} \frac{du}{dt} \\ \frac{d^2u}{dr^2} &= \frac{d}{dr} \left( \frac{du}{dt} \frac{dt}{dr} \right) = \frac{d^2u}{dt^2} \frac{dt}{dr} \frac{dt}{dr} + \frac{du}{dt} \frac{d^2t}{dr^2} = \frac{1}{r^2} \frac{d^2u}{dt^2} - \frac{1}{r^2} \frac{du}{dt} \end{aligned} \quad (4.3.29)$$

The differential equation becomes

$$\frac{d^2u}{dt^2} - u = 0 \quad (4.3.30)$$

which is an ordinary differential equation with constant coefficients. With  $u = e^{\lambda t}$ , one has the characteristic equation  $\lambda^2 - 1 = 0$  and hence the solution

$$\begin{aligned} u &= C_1 e^{+t} + C_2 e^{-t} \\ &= C_1 r + C_2 \frac{1}{r} \end{aligned} \quad (4.3.31)$$



**Solution to Eqn. 4.3.24**

The solution procedure for 4.3.24 is similar to that given above for 4.3.6. Using the substitution  $r = e^t$  leads to the differential equation with constant coefficients

$$\frac{d^4\phi}{dt^4} - 4\frac{d^3\phi}{dt^3} + 4\frac{d^2\phi}{dt^2} = 0 \quad (4.3.32)$$

which, with  $\phi = e^{\lambda t}$ , has the characteristic equation  $\lambda^2(\lambda - 2)^2 = 0$ . This gives the repeated roots solution

$$\phi = At + Bte^{2t} + Ce^{2t} + D \quad (4.3.33)$$

and hence 4.3.24.

## 4.4 Rotating Discs

### 4.4.1 The Rotating Disc

Consider a thin disc rotating with constant angular velocity  $\omega$ , Fig. 4.4.1. Material particles are subjected to a centripetal acceleration  $a_r = -r\omega^2$ . The subscript  $r$  indicates an acceleration in the radial direction and the minus sign indicates that the particles are accelerating towards the centre of the disc.

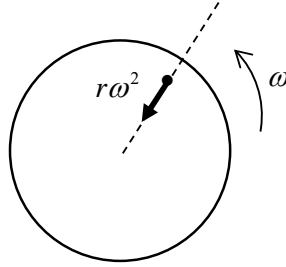

**Figure 4.4.1: the rotating disc**

The accelerations lead to an inertial force (per unit volume)  $F_a = -\rho r\omega^2$  which in turn leads to stresses in the disc. The inertial force is an axisymmetric “loading” and so this is an axisymmetric problem. The axisymmetric equation of equilibrium is given by 4.3.5. Adding in the acceleration term gives the corresponding equation of motion:

$$\frac{\partial \sigma_{rr}}{\partial r} + \frac{1}{r}(\sigma_{rr} - \sigma_{\theta\theta}) = -\rho r\omega^2, \quad (4.4.1)$$

This equation can be expressed as

$$\frac{\partial \sigma_{rr}}{\partial r} + \frac{1}{r}(\sigma_{rr} - \sigma_{\theta\theta}) + b_r = 0, \quad (4.4.2)$$

where  $b_r = \rho r\omega^2$ . Thus the dynamic rotating disc problem has been converted into an equivalent static problem of a disc subjected to a known body force. Note that, in a general dynamic problem, and unlike here, one does not know what the accelerations are – they have to be found as part of the solution procedure.

Using the strain-displacement relations 4.3.2 and the plane stress Hooke’s law 4.3.3 then leads to the differential equation

$$\frac{d^2 u}{dr^2} + \frac{1}{r} \frac{du}{dr} - \frac{1}{r^2} u = -\frac{1-\nu^2}{E} \rho r\omega^2 \quad (4.4.3)$$

This is Eqn. 4.3.6 with a non-homogeneous term. The solution is derived in the Appendix to this section, §4.4.3:

$$u = C_1 r + C_2 \frac{1}{r} - \frac{1}{8} \frac{1-\nu^2}{E} \rho r^3 \omega^2 \quad (4.4.4)$$

As in §4.3.4, let  $A = -EC_2 / (1+\nu)$  and  $C = EC_1 / 2(1-\nu)$ , and the full general solution is, using 4.3.2 and 4.3.3, {▲ Problem 1}

$$\begin{aligned} \sigma_{rr} &= +A \frac{1}{r^2} + 2C - \frac{1}{8} (3+\nu) \rho \omega^2 r^2 \\ \sigma_{\theta\theta} &= -A \frac{1}{r^2} + 2C - \frac{1}{8} (1+3\nu) \rho \omega^2 r^2 \\ \varepsilon_{rr} &= \frac{1}{E} \left[ + (1+\nu) \frac{A}{r^2} + 2(1-\nu)C - \frac{3}{8} (1-\nu^2) \rho \omega^2 r^2 \right] \\ \varepsilon_{\theta\theta} &= \frac{1}{E} \left[ - (1+\nu) \frac{A}{r^2} + 2(1-\nu)C - \frac{1}{8} (1-\nu^2) \rho \omega^2 r^2 \right] \\ u &= \frac{1}{E} \left[ - (1+\nu) \frac{A}{r} + 2(1-\nu)Cr - \frac{1}{8} (1-\nu^2) \rho \omega^2 r^3 \right] \end{aligned} \quad (4.4.5)$$

which reduce to 4.3.9 when  $\omega = 0$ .

### A Solid Disc

For a solid disc,  $A$  in 4.4.5 must be zero to ensure finite stresses and strains at  $r = 0$ .  $C$  is then obtained from the boundary condition  $\sigma_{rr}(b) = 0$ , where  $b$  is the disc radius:

$$A = 0, \quad C = \frac{1}{16} (3+\nu) \rho \omega^2 b^2 \quad (4.4.6)$$

The stresses and displacements are

$$\begin{aligned} \sigma_{rr}(r) &= \frac{3+\nu}{8} \rho \omega^2 [b^2 - r^2] \\ \sigma_{\theta\theta}(r) &= \frac{3+\nu}{8} \rho \omega^2 \left[ b^2 - \frac{1+3\nu}{3+\nu} r^2 \right] \\ u(r) &= \frac{3+\nu}{8} \rho \omega^2 \frac{1-\nu}{E} r \left[ b^2 - \frac{1+\nu}{3+\nu} r^2 \right] \end{aligned} \quad (4.4.7)$$

Note that the displacement is zero at the disc centre, as it must be, but the strains (and hence stresses) do not have to be, and are not, zero there.

Dimensionless stress and displacement are plotted in Fig. 4.4.2 for the case of  $\nu = 0.3$ . The maximum stress occurs at  $r = 0$ , where

$$\sigma_{rr}(0) = \sigma_{\theta\theta}(0) = \frac{3+\nu}{8} \rho \omega^2 b^2 \quad (4.4.8)$$

The disc expands by an amount

$$u(b) = \frac{1-\nu}{4E} \rho \omega^2 b^3 \quad (4.4.9)$$

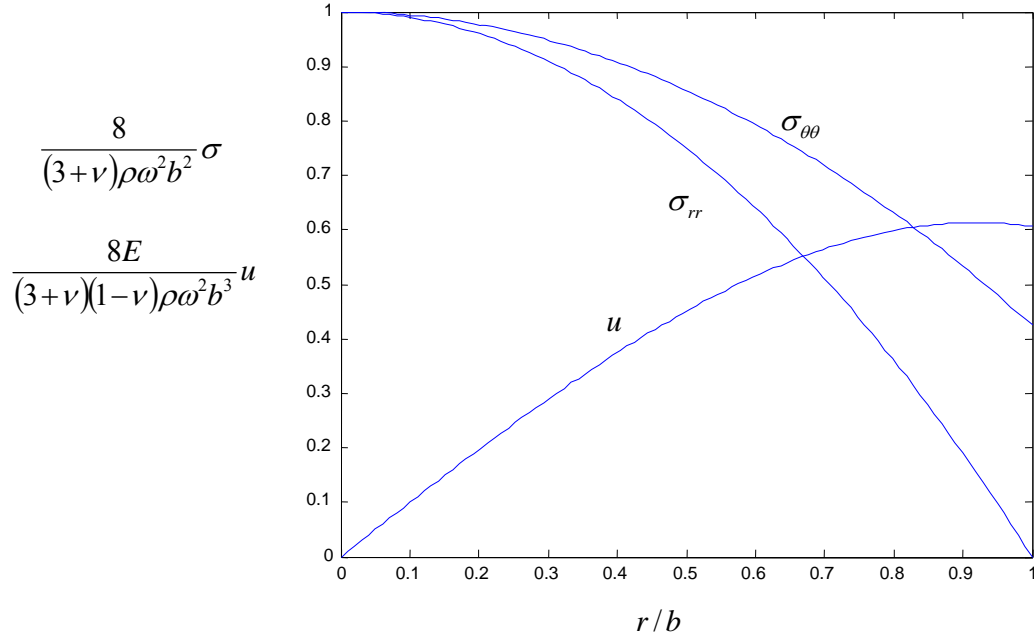

**Figure 4.4.2: stresses and displacements in the solid rotating disc**

### A Hollow Disc

The boundary conditions for the hollow disc are

$$\sigma_{rr}(a) = 0, \quad \sigma_{rr}(b) = 0 \quad (4.4.10)$$

where  $a$  and  $b$  are the inner and outer radii respectively. It follows from 4.4.5 that

$$A = -\frac{1}{8}(3+\nu)\rho\omega^2 a^2 b^2, \quad C = \frac{1}{16}(3+\nu)\rho\omega^2 (a^2 + b^2) \quad (4.4.11)$$

and the stresses and displacement are

$$\begin{aligned} \sigma_{rr}(r) &= \frac{3+\nu}{8} \rho \omega^2 \left[ a^2 + b^2 - r^2 - \frac{a^2 b^2}{r^2} \right] \\ \sigma_{\theta\theta}(r) &= \frac{3+\nu}{8} \rho \omega^2 \left[ a^2 + b^2 - \frac{1+3\nu}{3+\nu} r^2 + \frac{a^2 b^2}{r^2} \right] \\ u(r) &= \frac{3+\nu}{8} \rho \omega^2 \frac{1-\nu}{E} r \left[ a^2 + b^2 - \frac{1+\nu}{3+\nu} r^2 + \frac{1+\nu}{1-\nu} \frac{a^2 b^2}{r^2} \right] \end{aligned} \quad (4.4.12)$$

which reduce to 4.4.7 when  $a = 0$ .

Dimensionless stress and displacement are plotted in Fig. 4.4.3 for the case of  $\nu = 0.3$  and  $a/b = 0.2$ . The maximum stress occurs at the inner surface, where

$$\sigma_{\theta\theta}(0) = \frac{3+\nu}{4} \rho \omega^2 b^2 \left[ 1 + \frac{1-\nu}{3+\nu} (a/b^2) \right] \quad (4.4.13)$$

which is approximately twice the solid-disc maximum stress.

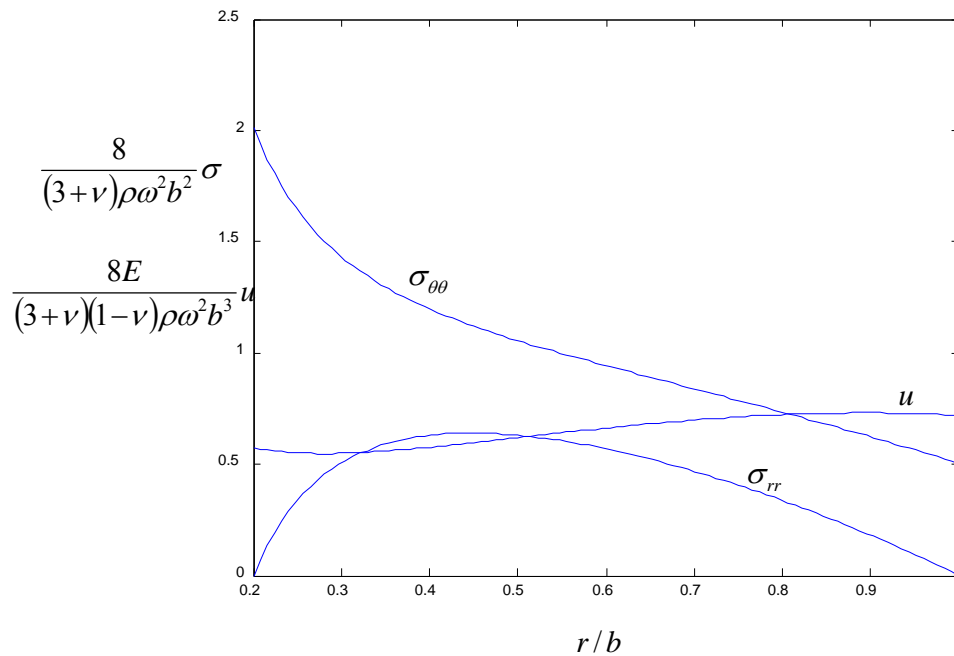

**Figure 4.4.3: stresses and displacements in the hollow rotating disc**

## 4.4.2 Problems

1. Derive the full solution equations 4.4.5 for the thin rotating disc, from the displacement solution 4.4.4.

## 4.4.3 Appendix: Solution to Eqn. 4.4.3

As in §4.3.8, transform Eqn. 4.4.3 using  $r = e^t$  into

$$\frac{d^2 u}{dt^2} - u = -\frac{1-\nu^2}{E} \rho e^{3t} \omega^2 \quad (4.4.14)$$

The homogeneous solution is given by 4.3.31. Assume a particular solution of the form  $u_p = Ae^{3t}$  which, from 4.4.14, gives

$$u_p = -\frac{1}{8} \frac{1-\nu^2}{E} \rho \omega^2 e^{3t} \quad (4.4.15)$$

Adding together the homogeneous and particular solutions and transforming back to  $r$ 's then gives 4.4.4.